

KOBELT

2048 Control Head

*Owner's Operation, Installation &
Maintenance Manual*



Table of Contents

1	Introduction	4
1.1	Contact	4
1.2	Safety	4
1.2.1	Safety Alerts	4
1.2.2	Notice to Installer.....	4
1.2.3	Product Hazards	5
2	Product Description	6
2.1	Overview.....	6
2.2	Technical Data	7
2.3	Model Code Key.....	8
3	Installation	9
3.1	Receipt.....	9
3.2	Mechanical	9
3.3	Control Cable	9
3.3.1	Hardware.....	9
3.3.2	Cable Routing	10
3.3.3	Connection and Extension Kits.....	11
3.3.4	Control Head Connection.....	12
3.3.5	Actuator End Connection	14
3.4	Electrical	14
4	Commissioning	15
4.1	Inspection	15
4.2	Functional Test	15
5	Operation	16
6	Maintenance	16
6.1	Preventative Maintenance	16
6.1.1	LUBRICATION INSTRUCTIONS.....	16
6.2	Inspection	16
6.3	Recommended Spare Parts and Kits	19
6.4	Troubleshooting	19
7	Warranty	20
8	Revision History.....	21
9	Appendix A: Installation Dimensions	21
10	Appendix B: Parts List	23
11	Appendix C: Installation Cut-out Template.....	26

1 INTRODUCTION

1.1 CONTACT

Kobelt Manufacturing Co. Ltd.
8238 129th Street
Surrey, British Columbia
Canada, V3W 0A6

Sales Tel: +1-604-572-3935
Fax: +1-604-590-8313
Email: sales@kobelt.com
Website: www.kobelt.com





This document is intended to clearly present comprehensive product data and provide technical information to assist the end user in design applications. Kobelt reserves the right, without notice, to change the design, or construction, of any products and to discontinue or limit distribution of any products. Kobelt also reserves the right to change, or update, without notice, any technical information contained within this document.

Kobelt recommends that customers visit our website to check for updates to this Manual. Once a product has been selected for use, it should be tested by the user to ensure proper function in all possible applications. For further instructions, please contact our distributors or visit our website.

1.2 SAFETY

1.2.1 Safety Alerts

Throughout this manual, the following symbols, and their accompanying explanation, are used to alert the user to special instructions concerning a service or operation that may be hazardous if performed incorrectly or carelessly. The associated risk levels are stated below.

 DANGER	This symbol indicates an imminently hazardous situation which, if not avoided, will result in death or serious injury.
 WARNING	This symbol indicates a potentially hazardous situation which, if not avoided, could result in death or serious injury.
 CAUTION	This symbol indicates a hazardous situation, which if not avoided, could result in minor or moderate injury.
 NOTICE	This symbol informs the reader of events not related to personal injury but which there is a risk of damage to property or equipment.
 SAFETY INSTRUCTIONS	This symbol informs the reader of safety-related instructions or procedures.

1.2.2 Notice to Installer

Disregarding the following safety measures can result in an accident causing severe injury to personnel and damage to material assets.

- Only use the product as directed in this manual.
- Never put the product into service if there is evidence of visible damage.
- Never put the product into service before fully completing installation and commissioning.
- Do not carry out any modifications to the product.

- Only use authentic Kobelt spare parts.
- Observe all local regulations, directives and laws during the installation of this product.
- All installation, commissioning, and maintenance work must only be conducted by qualified personnel. (For the purpose of this manual, qualified personnel are persons who are familiar with the assembly, installation, commissioning, and operation of the product and who have the qualifications necessary for their occupation.)
- Observe all specifications in this manual. If these guidelines are not followed and damage occurs, the warranty will be voided.

1.2.3 Product Hazards

 WARNING	Equipment Starts Automatically: Vessel propulsion may activate suddenly while servicing this product, causing bodily harm. Ensure that all power sources are locked out prior to performing work.
--	---

 WARNING	Pinch Points: The 2048 control head contains pinch points, which can cause bodily harm. Ensure that hands and fingers remain clear of the pinch points when performing work.
--	--

2 PRODUCT DESCRIPTION

2.1 OVERVIEW

The Kobelt 2048 push-pull control head features twin-engine control with both the clutch and throttle control integrated into each lever. More specifically, this control head is intended to control two transmissions with lever type shift valves and two engines with lever type throttle control. The control head also features a spring-loaded throttle override which permits running the engine with the clutch disengaged.

The 2048 is available in a combination of black and chrome, all black, or all polished chrome to suit your appearance preference. Accessories, such as neutral safety switch kits or throttle extension kits can be ordered with the units or as after market parts.

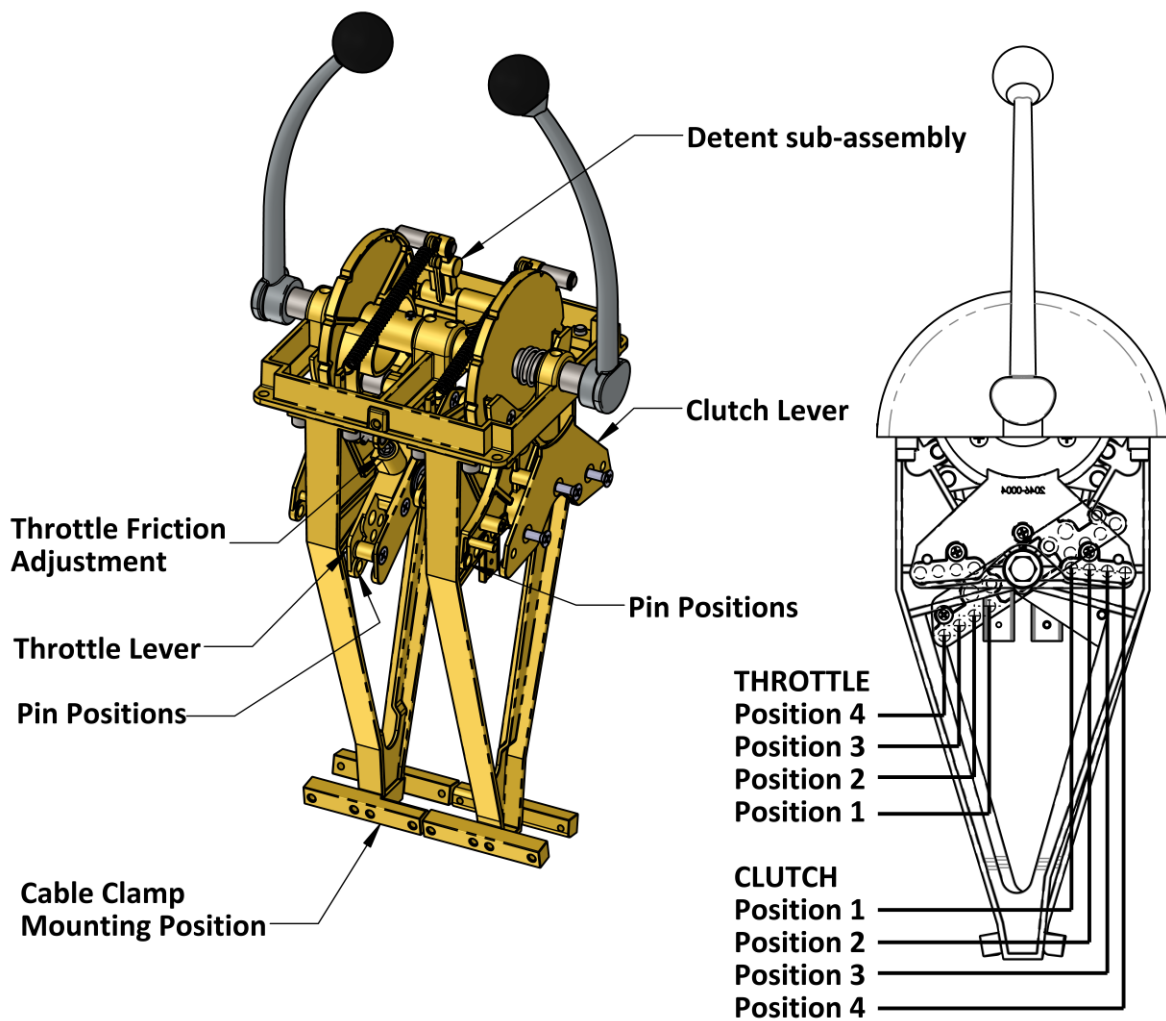

2.2 TECHNICAL DATA

Handle Travel:

- Neutral: 0° Detented
- Clutch engage: +/- 30° Detented
- Full throttle: +/- 85° -
- Over-travel:¹ 92° Detented

Pin position:	1	2	3	4
Stroke:				
• Clutch stroke:	±0.66 in [±17 mm]	±0.93 in [±24 mm]	±1.20 in [±30 mm]	±1.48 in [±38 mm]
• Throttle stroke:	0.86 in [22 mm]	1.21 in [31 mm]	1.55 in [39 mm]	1.90 in [48 mm]
Maximum Output Force ² :				
• Clutch stroke:	147 lbf [654 N]	106 lbf [472 N]	83 lbf [369 N]	68 lbf [302 N]
• Throttle stroke:	121 lbf [539 N]	90 lbf [399 N]	71 lbf [315 N]	59 lbf [261 N]
Lever ratio:				
• Clutch:	5.1:1	3.7:1	2.9:1	2.4:1
• Throttle ³ :	4.2:1	3.1:1	2.4:1	2.0:1

Ambient Temperature: -40°F...+140°F [-40 °C... + 60 °C]

Weight: 14.4 lbs [6.5 kg]

- 1) Forward direction only.
- 2) Estimated output force is at end of stroke based on an input force of 29 lbf on a "Tee" handle. Output force must not exceed rated cable force.
- 3) At end of stroke, lever ratio increases towards neutral.

2.3 MODEL CODE KEY

The 2048 control head can be configured in several different ways. Below is a key defining the letter code options:

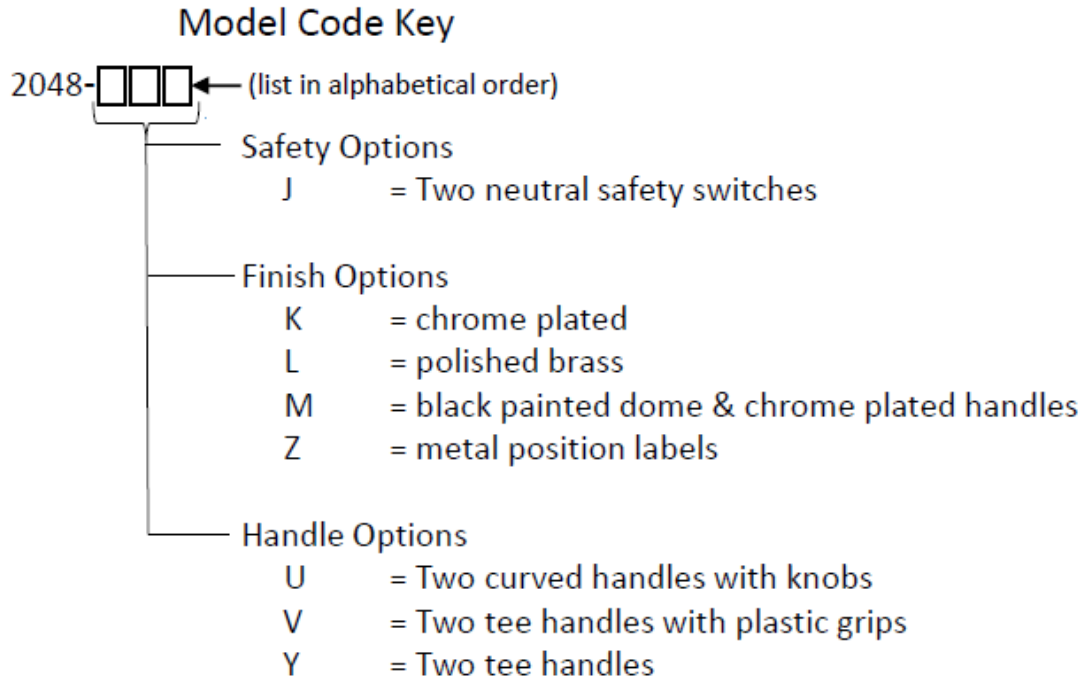

3 INSTALLATION

3.1 RECEIPT

Kobel offers the 2047 control head in several configurations (reference [section 2.3](#)). Upon receipt of the device ensure that the model number and serial number are noted on the table in page 2 of this manual. The serial number can be found in the location noted at right. This model number will determine what spare parts are applicable.

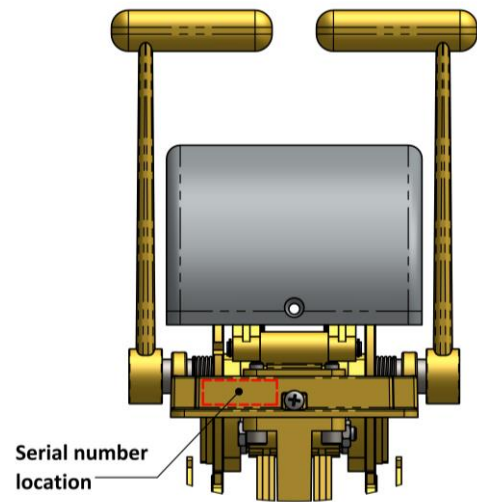

3.2 MECHANICAL

The control head must be mounted on a flat surface strong and stiff enough to withstand the cable forces listed in the technical section without excessive flexing. Choose a location that has sufficient room for the handles in both extreme positions.

The control head is equipped with (4) four clearance holes for #10 (M5) screws or bolts inserted from underneath for direct mounting to the dash. Ensure the unit is securely fastened, preferable with an anaerobic thread locker such as Loctite 243. Before securing the screws, ensure the detent roller mechanism is in the forward position.

3.3 CONTROL CABLE

3.3.1 Hardware

The 2048 control head can be used with either 30 series or 40 series control cable. Kobelt Manufacturing does not recommend solid core cables. A solid core cable would consist of a single wire that is too stiff. Multi-stranded cores are more flexible and therefore generates less friction during operation.

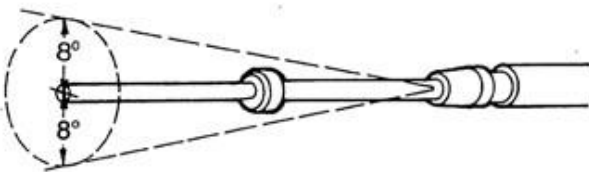

The cable ends must also be able to articulate approximately 8 degrees in either direction.

For terminating the cables Kobelt recommends a ball rod end. Rod ends are self-aligning and cannot and therefore minimize friction and binding.

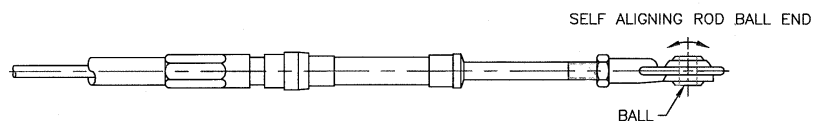

When installing hardware to the cable end, do not twist the core. If required, use a pair of pliers to hold the cable core from turning while installing the terminating hardware. When gripping the cable end, apply the pliers immediately under the threads and take care not to score the cable rod. A scored cable rod will damage the cable seal allowing moisture and dirt to enter the casing.

3.3.2 Cable Routing

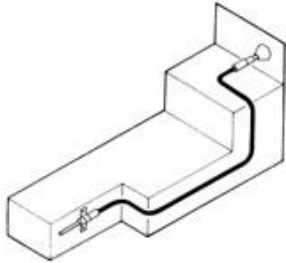

Measure the cable along the path it will take from where the cable hubs will be anchored at each end. Follow the actual cable path as closely as possible, allowing for the largest practical bend radii.

Do not force the cable into tighter bends than what is listed in the table at right:

<i>Optimum Life Bend Radii</i>	
<i>Cable Size</i>	<i>Minimum bend radii</i>
30 series	3 inches ¹ [76 mm]
40 series	4 inches [127 mm]

1) Solid core cables will require 6 in [152 mm] minimum bend radius.

It is important to securely anchor the cable hubs. Any free-play in the cable clamp or mounting bracket will be perceived as lost motion or “sponginess” and will reduce the detent feel.

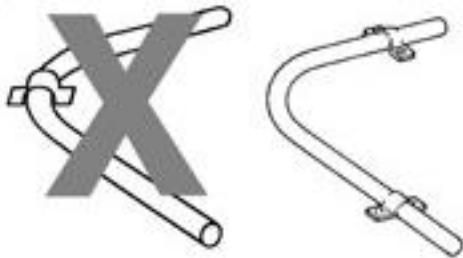

When securing the cable with clamps, it is recommended practice to position two clamps at the ends of the bend rather than one in the middle.

When installing a push-pull cable, do not kink the cable since this will permanently damage the core and casing, rendering the cable stiff and inoperable. Even minor kinks will result in premature failure.

It should also be noted to avoid routing the cable near sources of heat, such as exhaust pipes or cold, such as refrigerated fish holds.

3.3.3 Connection and Extension Kits

To install the 2048 push/pull control head, the appropriate connection kit must be purchased. Consult the table below for the correct kit:

Table 1: Connection Kits

Use Case	Kit Number
Clutch - 30 series cable	2046-0901
Clutch - 40 series cable	2046-0902
Throttle - 30 series cable	2046-0901
Throttle - 40 series cable	2046-0902

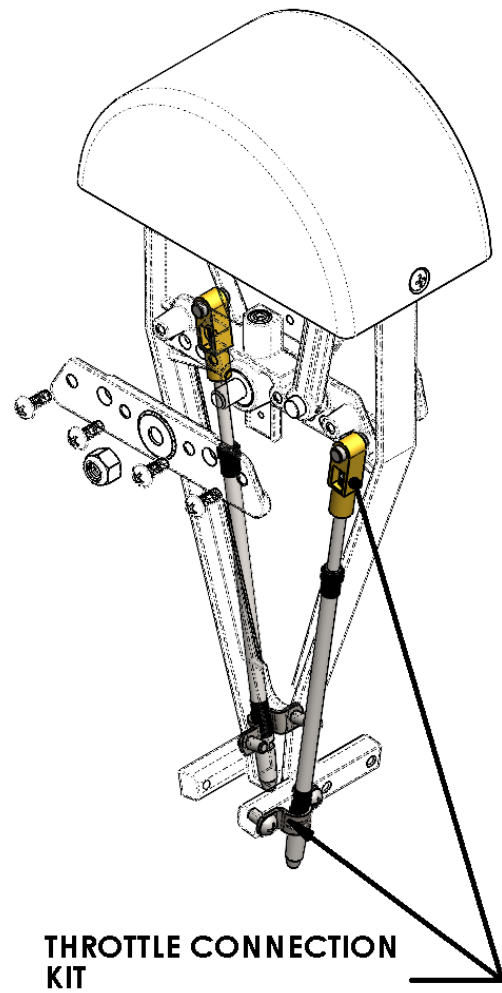
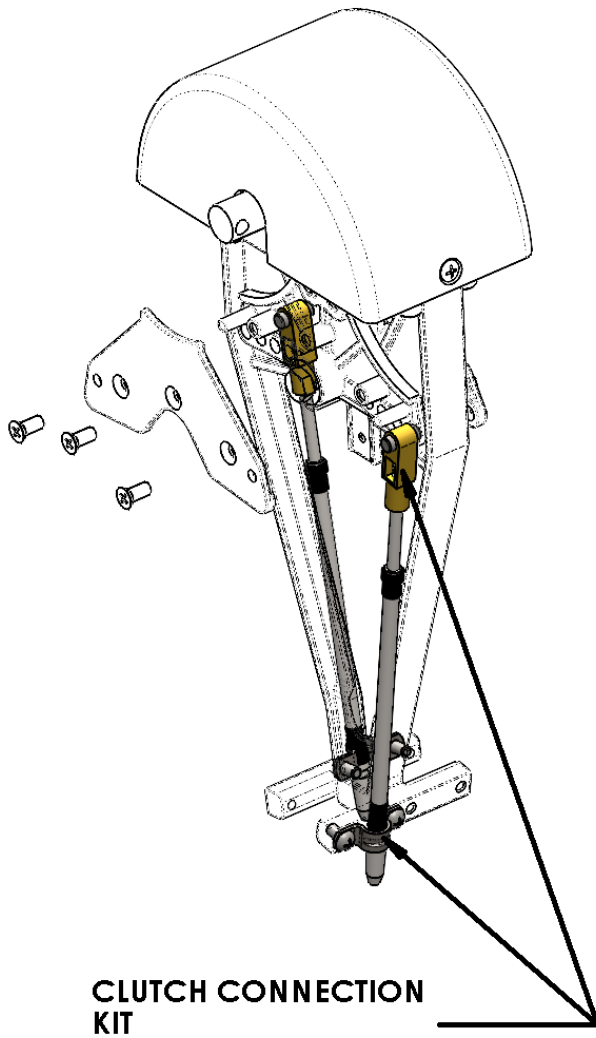

Clutch and throttle extension kits are also available for equipment that require more than the standard stroke output. Consult the table below for the correct kit part number:

Table 2: Extension Kits

Use Case	Kit Number
Clutch - 30 series cable	2046-0905
Clutch - 40 series cable	2046-0906
Throttle - 30 series cable	2046-0905
Throttle - 40 series cable	2046-0906

Note that the 2048 extension kits include the connection hardware.

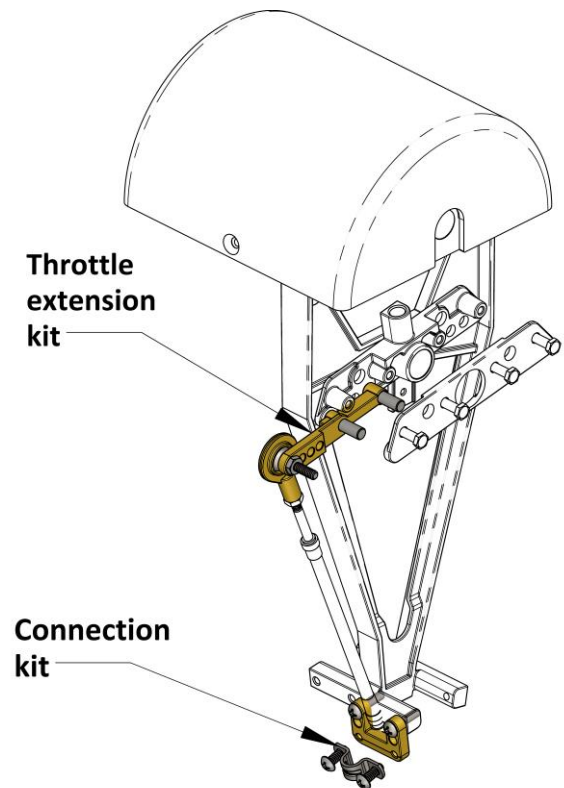

3.3.4 Control Head Connection

The 2048 control head has a lever mechanism for actuating the clutch and the throttle that permits the cable to be installed in either push or pull.

In some marine applications with twin engines, both engines are turning in the same direction and therefore one gear box is running in the reverse to drive the propeller ahead. In this particular installation the shift cable must be connected on the opposite side of the support bracket and cam to provide the proper push and pull mode for either gear.

The clutch valve mechanism on most marine transmission requires approximately 2¾" (70 mm) to 3" (76 mm) of travel. Consequently, the cable must be attached on the clutch lever, item "A", in the outermost hole of the support bracket (pin position 4).

To correctly install the clutch control cables, follow the steps below:

1. Secure the cables to the support bracket with the appropriate cable clamps.
2. As illustrated in the diagram below, move the control handles to the extreme forward position.
3. Ensure that the cable end extends slightly past the clutch lever attachment point (position A).
4. Move the control handles to the extreme aft position.
5. Ensure that the cable end, when in push mode, extends beyond the cable attachment point (position B).
6. If the cable end points from one extreme to the other are unequal, then the cable end fitting must be threaded out or in to correct.
7. Repeat steps 2 to 6
8. After the proper position is found, the cable end is attached to the clutch actuating pivot plate and the jam nut tightened.
9. The final step is to test that the clutch control valve goes from neutral to both forward and then reverse gear engaged positions without bottoming. A slight amount of end play is essential.

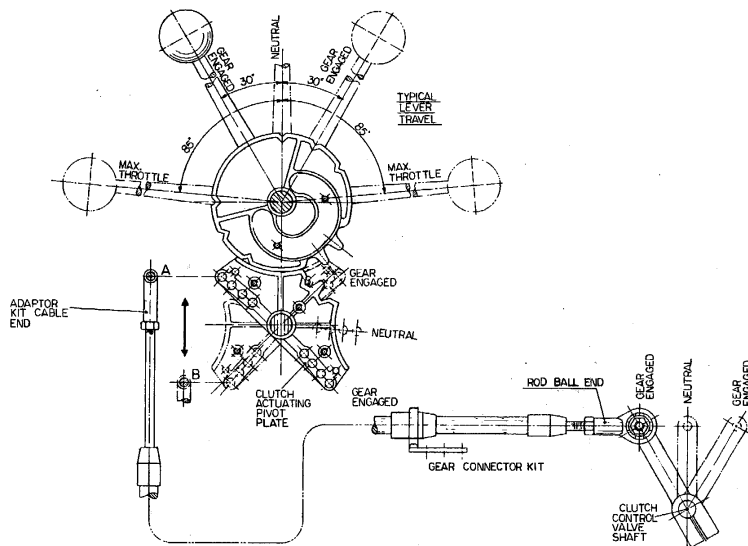
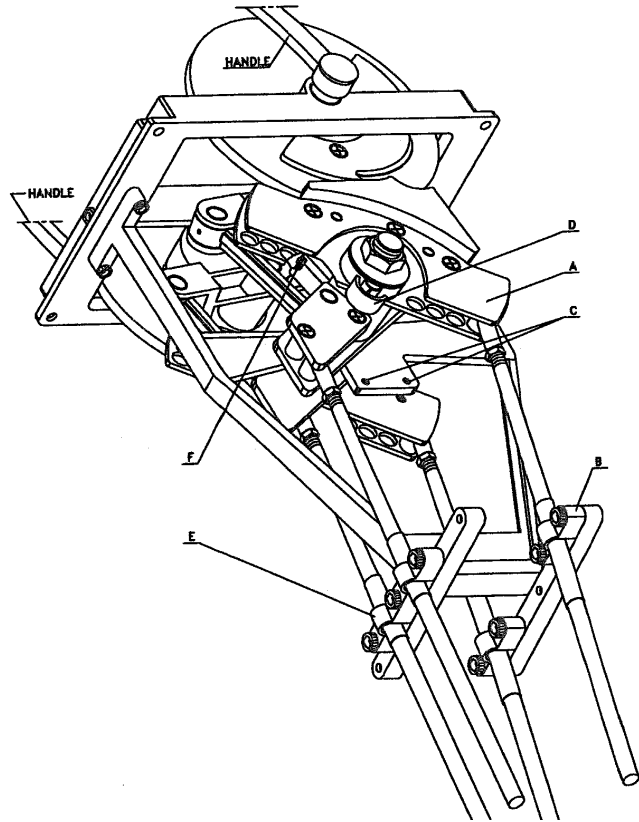

The throttle cable is installed in the same manner. In order to obtain full handle travel in the speed range, it is important to select the appropriate connection point for the adaptor kit on the throttle pivot plate.

3.3.5 Actuator End Connection

When connecting the actuating end of the cable to the throttle or clutch lever, install the cable so that the greatest loads are in tension (pulling) rather than compression (pushing), if possible.

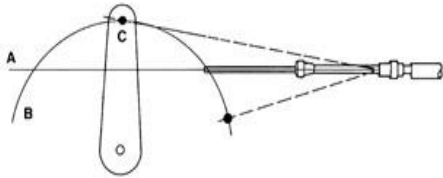
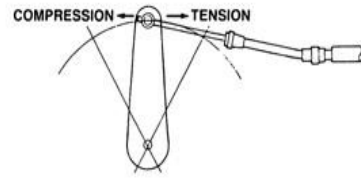

Where the cable is connected to a lever, the cable must be mounted so that it lies on a plane (A) midway on the arc (B) described by the movement of the connection point on the lever (C).

When connecting the actuating end of the cable to a spool valve such as the Kobelt 4605 servo cylinder, maximum cable life and efficiency is achieved when the cable is aligned with the lever in two planes. Reference the figure at right:

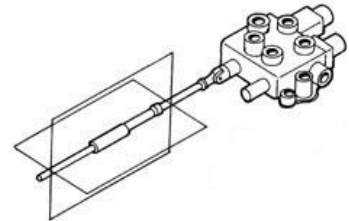

3.4 ELECTRICAL

The 2048 control head is available with optional neutral safety switches (Two of a part number **2048-0903**). The switch kit attaches to the frame, as illustrated in the figure at right.

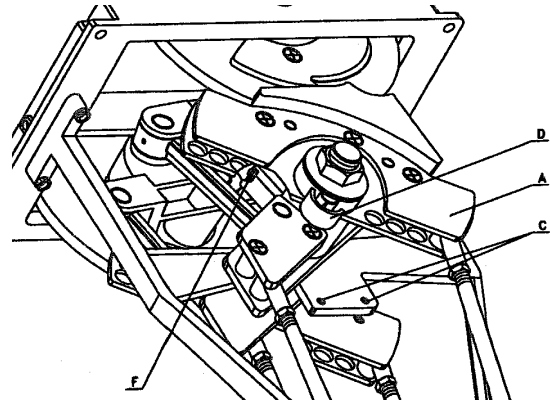

The switch is prewired with a 1 foot [305 mm] long 18 AWG wire for external connection. Connect it to an electrical junction box and the propulsion system interface.

The product's 3C/18 electrical cable contains the following wires and related functions:

Table 3: 2048 Wire Connections

2048-0903				
Wire #	Wire Name	Colour	Gauge	Function
1	N.O.	RED	18AWG	Connects to COM when Switch is activated to signal neutral position.
2	COM	Black	18AWG	COM connection.

4 COMMISSIONING

4.1 INSPECTION

Before putting the control head into operation, check the cable connections at each end to ensure that there is side clearance between the sleeve and the core rod and no misalignment at either the clamp or the control head which will make the cable stiff.

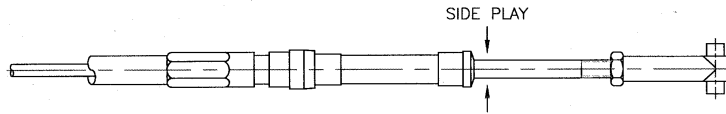

It is possible that a cable end may become bent either in transit or during installation. If this has occurred the cable must be replaced as it will bind between the core rod and the sleeve.



4.2 FUNCTIONAL TEST

After installation, test that the clutch control valve goes from neutral to both forward and then reverse gear engaged positions without bottoming. A slight amount of end play is essential.

Also ensure that full speed range is obtained with full handle travel.

Ensure that the throttle friction adjustment is adequate to hold the throttle position. Adjust if necessary.

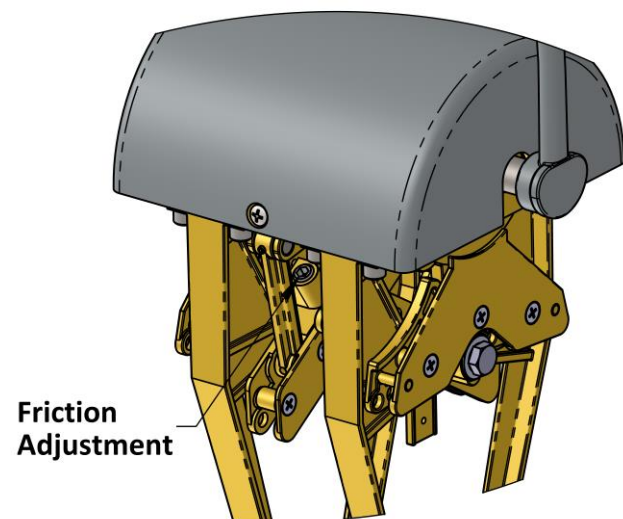

CAUTION

Do not put the vessel into service until the control head has been tested. The Functional Test should be carried out while the vessel is still at dock.

5 OPERATION

The Kobelt 2048 is equipped with a clutch bypass to permit operating the throttle without engaging the transmission into gear. To operate this feature, pull the handle outwards while in the neutral position and then operate the lever to the desired throttle position.

The control head is also equipped with full throttle detents in the forward position. This detent is engaged at the 92 degree position (over center).

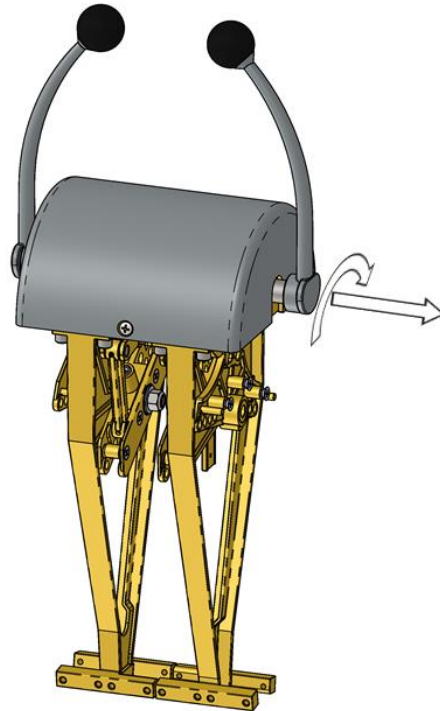

6 MAINTENANCE

6.1 PREVENTATIVE MAINTENANCE

- Quarterly (4 times per year)
 - Ensure that the throttle friction adjustment is adequate.
- Every 2 years
 - Inspect cable for wear
 - Lubricate pins & rollers
 - Inspect throttle & clutch bushings for wear

6.1.1 LUBRICATION INSTRUCTIONS

Follow the figures below to access and lubricate the bearing journals and detent tracks.

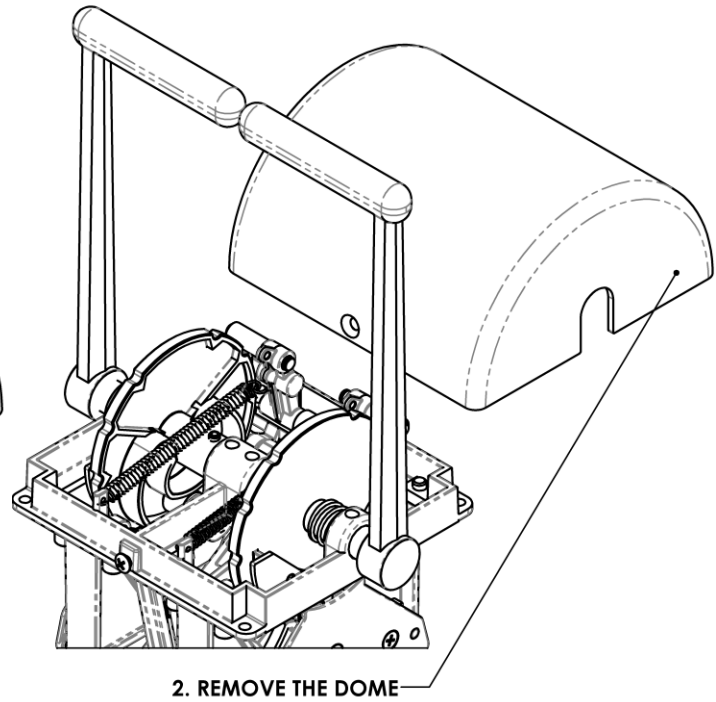
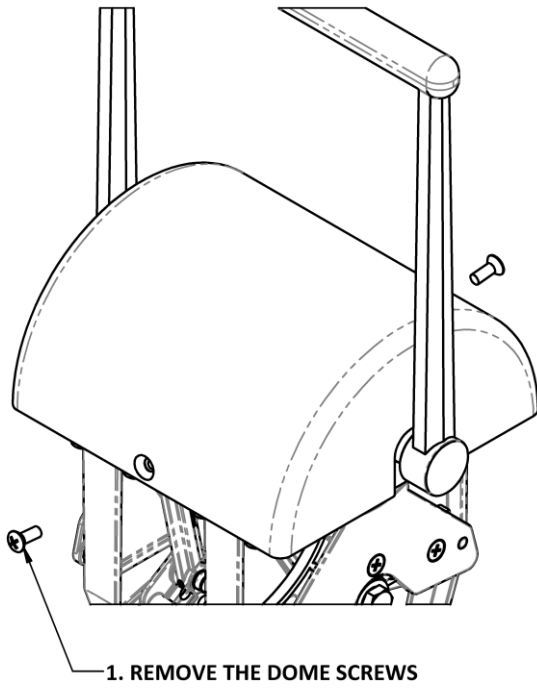

3. APPLY OIL AT INDICATED LOCATION

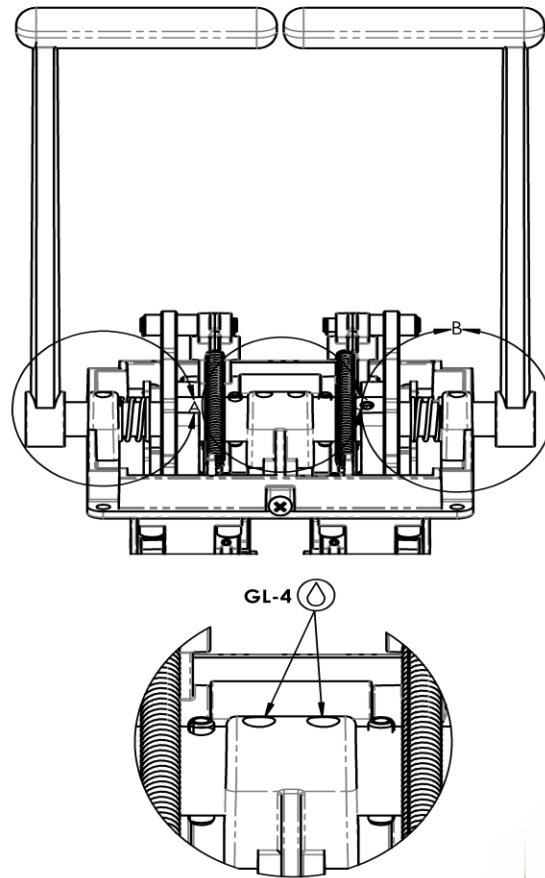
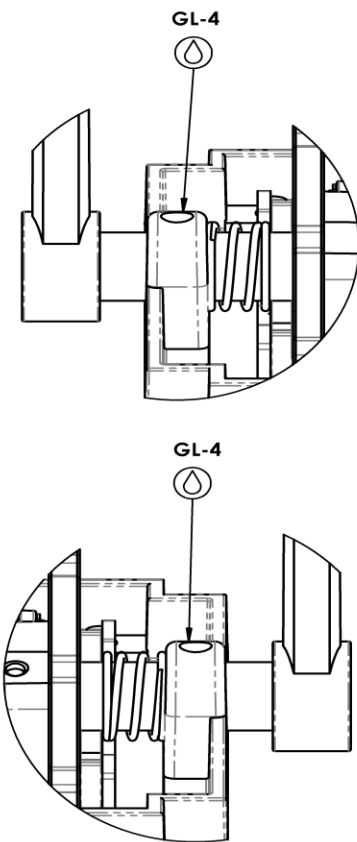

4. APPLY GREASE TO GEARS, DETENT TRACK AND ROLLER

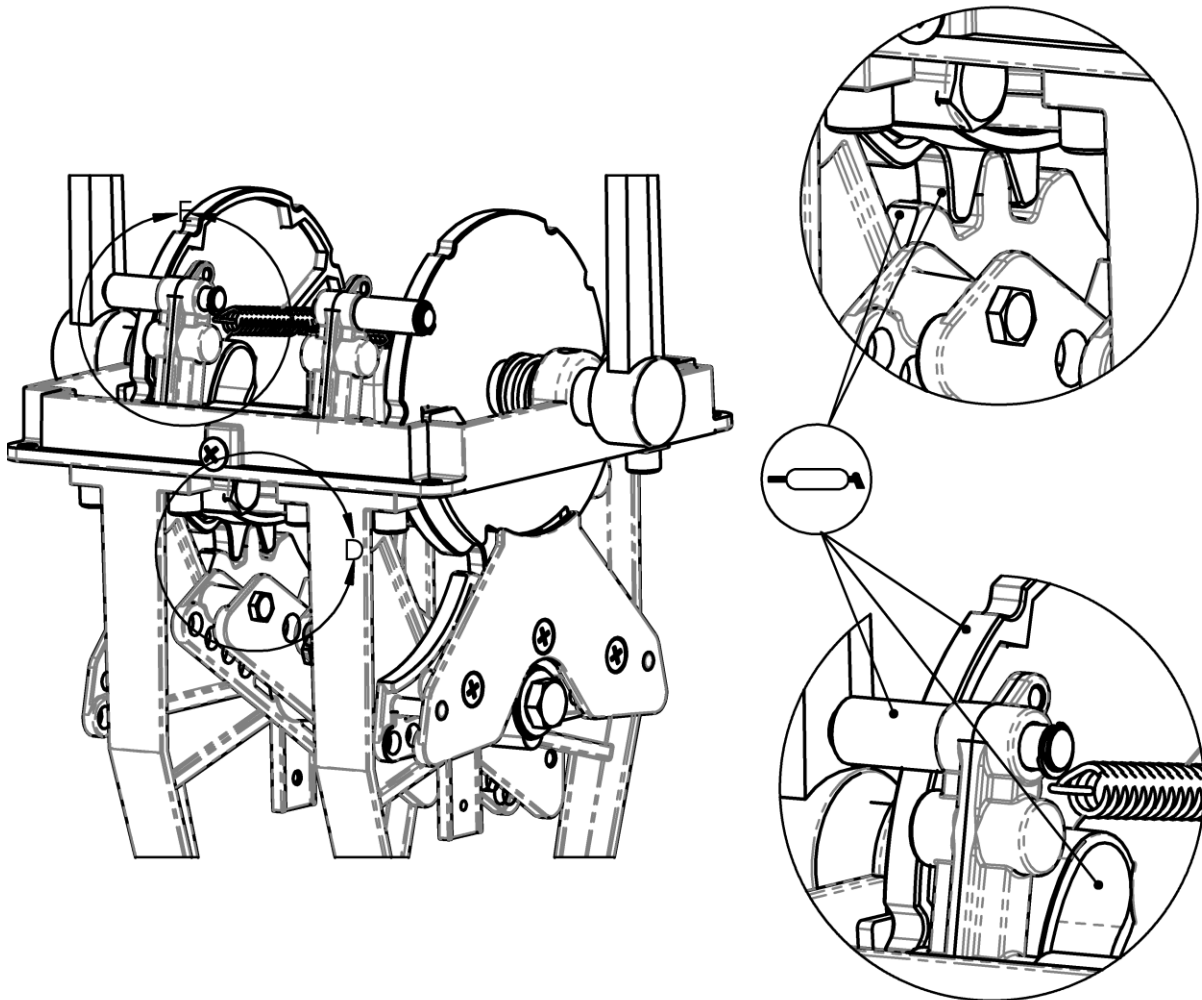
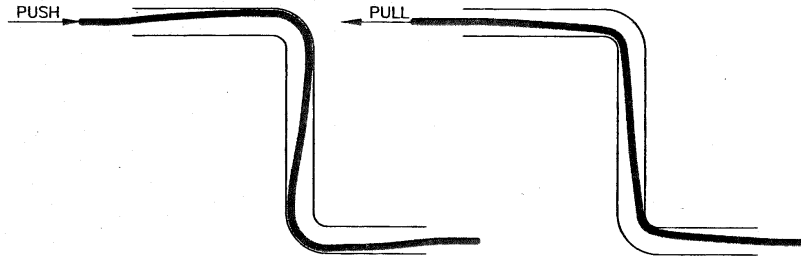

Table 4: Recommended Gear Lubricant & Grease

S. No.	Description	Grade
1	Valvoline gear oil	75w80 HD GL-4
2	Motul Transmission oil	80w-90 GL-4/GL-5
3	Phillips 66 Megaplex XD3 (Grease)	NLGI-2
4	Straplex HD 2 M5 (Grease)	NLGI-2

6.2 INSPECTION

When a cable core is pushed, it will take the longest route and, conversely, when pulled, it will take the shortest route. This appears as 'lost motion' at the actuation end. The cable stroke must be measured periodically to confirm adequate stroke.



6.3 RECOMMENDED SPARE PARTS AND KITS

The spare parts kept on hand will depend on the severity of the service. The User should monitor the condition of their control head to predict necessary spare parts and ensure they are on hand when needed.

When purchasing spare parts refer to Appendix B: Parts List at the back of this manual for Kobelt component Part Numbers.

NOTICE

It is recommended that any required service work on a Kobelt unit be performed by a factory authorized service representative. Please contact the nearest Kobelt authorized distributor for assistance.

6.4 TROUBLESHOOTING

If you encounter problems with the operation of your product, please refer to the trouble-shooting suggestions before contacting Kobelt for assistance. If the steps below do not resolve your issue, please reach out either Kobelt directly or our Dealers in your area.

Table 5: Common Solutions

Problem (Issue encountered)	Cause (What it means)	Corrective Action (What to do)
Full throttle not achieved	Lost motion in the cable – cable worn Lost motion in the cable – cable not clamped	1. Replace cable. 2. Clamp cable per manufacturer's recommended practice.
Controls stiff to operate	1. Wrong cable installed. 2. Cable has been kinked. 3. Cable operating below minimum allowable temperature.	1. Replace cable with flexible core type cable. 2. Replace cable. 3. Ensure cable does not run through a fish hold.

7 WARRANTY

Kobel Manufacturing Co. Ltd. (“Kobel”) warrants the Products and Parts manufactured by Kobel to be free from defects in workmanship or material and that said products are designed mechanically and functionally to perform to specifications.

This warranty is effective providing:

- The equipment is used within the intended operating conditions and in accordance with Kobel recommendations
- The equipment is installed according to equipment diagrams, specifications and recommendations which Kobel has provided

This warranty becomes invalid if the factory supplied serial number has been removed or altered on the product. This warranty does not cover cosmetic damage or damage caused by an act of God, accident, misuse, abuse, negligence or modification of any part of the product. This warranty does not cover damage due to improper operation or maintenance, connection to inappropriate equipment or attempted repair by anyone other than an authorized Kobel representative.

Upon identification of a potential issue or defect with a Kobel Product or Part, the Warranty Applicant (“Applicant”) must immediately contact Kobel and describe the issue in writing, by letter, fax, email or other electronic conveyance. Kobel will then assess the cause of the defect and determine warranty applicability and appropriate remediation.

If any part is found to be defective, Kobel will replace said part FOB the Kobel factory provided that any such defective part is returned by the Buyer with freight and applicable forwarding charges prepaid by the Buyer. Kobel’s sole obligation to the Applicant will be to repair or replace the defective part with same or similar product, to a maximum value of the list price of the product or part. The Kobel warranty does not cover labour charges, travel or any other associated expenses.

All Products and Parts manufactured by Kobel, are subject to a warranty against manufacturer’s defects in materials or workmanship for a period of two (2) years from the date of purchase.

Kobel will be responsible for all Products or Parts sold by Kobel but manufactured by 3rd party manufacturing companies. However, these products and parts are subject to applicable 3rd party warranties and may not be the same as the Kobel warranty.

8 REVISION HISTORY

Table 6: Revision History

Document Revision	Release Date	ECN	Author	Revision Summary
F	3/10/2024	01071	JS	<ul style="list-style-type: none"> Added maintenance details, section 6.1.1 Separated connection and extension kit depictions, section 3.3 Added Table 4: Recommended Gear Lubricant & Grease, Section 6.1.1
E	4/19/2024	00970	GG	<ul style="list-style-type: none"> Updated section 2.2 technical specifications Added long tee handle dimensions to Appendix A: Installation dimensions. Clarified Optimum life bend radii table, column No.2 header; was "Operating life minimum".
D	N/A	-	N/A	<ul style="list-style-type: none"> Added receipt instructions, section 3.1 Added section 3.3.3: Connection and extension kits
C	N/A	-	N/A	<ul style="list-style-type: none"> Corrected Table 1 wire connections, previously called 7170 wire connections.
B	N/A	-	N/A	N/A
A	N/A	-	N/A	<ul style="list-style-type: none"> Initial publication

9 APPENDIX A: INSTALLATION DIMENSIONS

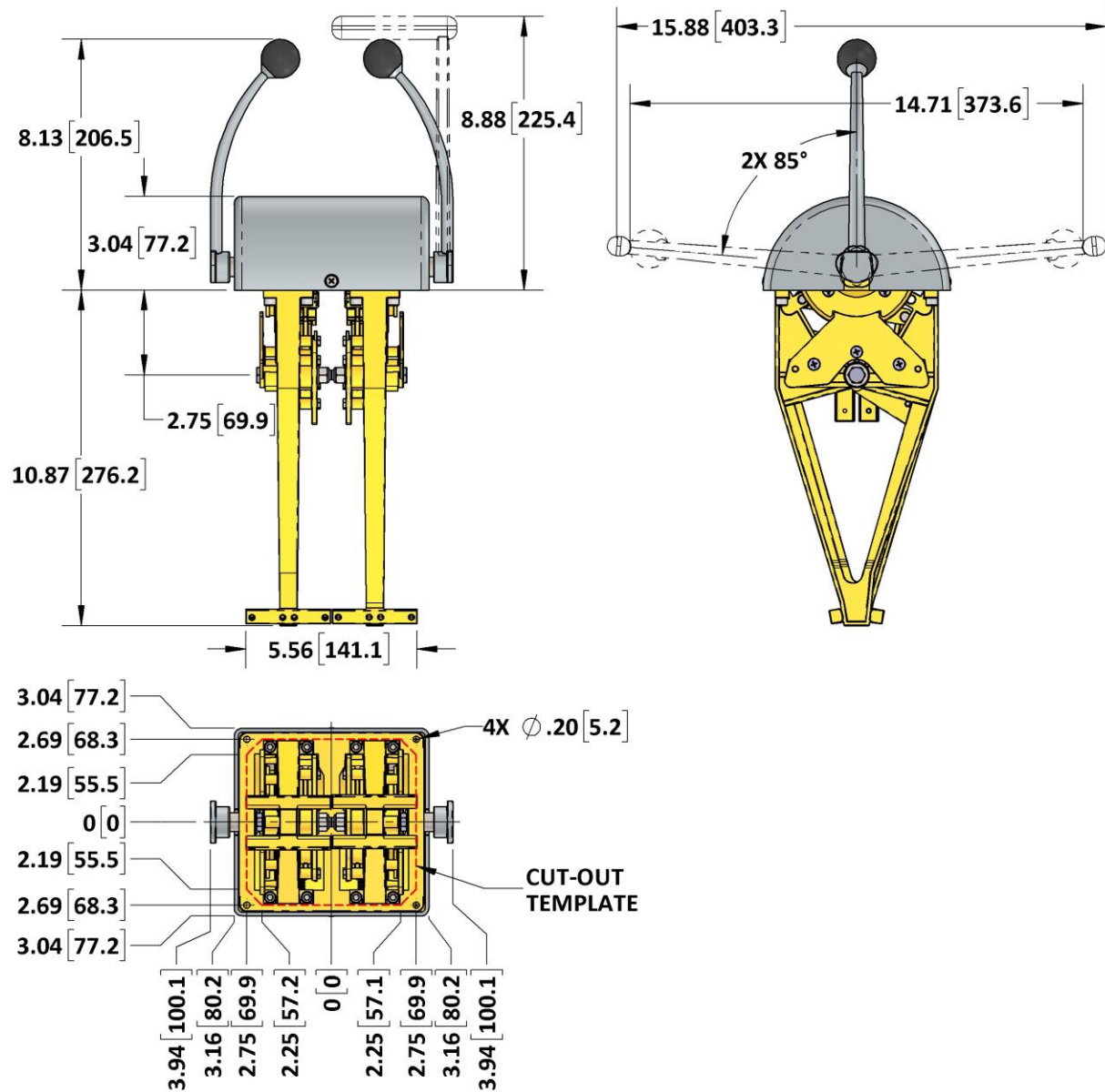
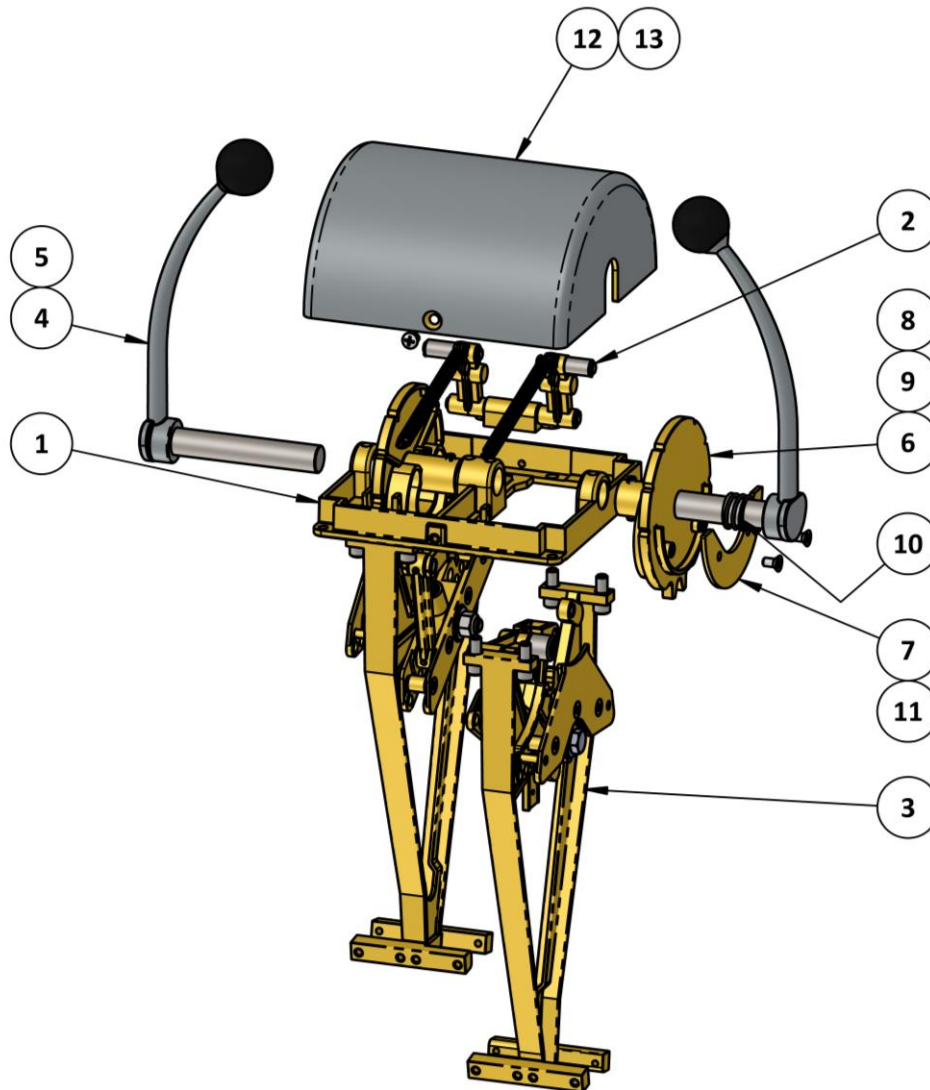

Figure 18: 2048 Installation Dimensions

10 APPENDIX B: PARTS LIST



ITEM	QTY.	PART NUMBER	DESCRIPTION
1	1	2048-0001	FRAME
2	1	2048-1000	SUB ASSEMBLY, DETENT ROLLERS
3	2	2048-2000	SUB ASSEMBLY; CLUTCH & THROTTLE LEVERS
4	2	2046-0012	HANDLE, CURVED
5	2	2030-0001	KNOB, BLACK
6	2	2046-0002	CENTRE CAM
7	2	2046-0011	CAM RETAINER
8	2	1016-0804	SET SCREW 10-24 X 1/4, SS
9	2	1024-0816	PIN, .1875 DIAMETER
10	2	1201-0108	SPRING, COMPRESSION, .8125 X .0625 X 1.00
11	4	1009-0806	SCREW, FLAT HD, PHL, 10-24 X 3/8, 18-8
12	1	2048-0002-K	DOMES; CHROME PLATED
13	2	1005-0808	SCREW, OVAL HD, PHILLIPS, 10-24 X 1/2, 18-8

2048-1000 Detent Roller Sub-Assembly

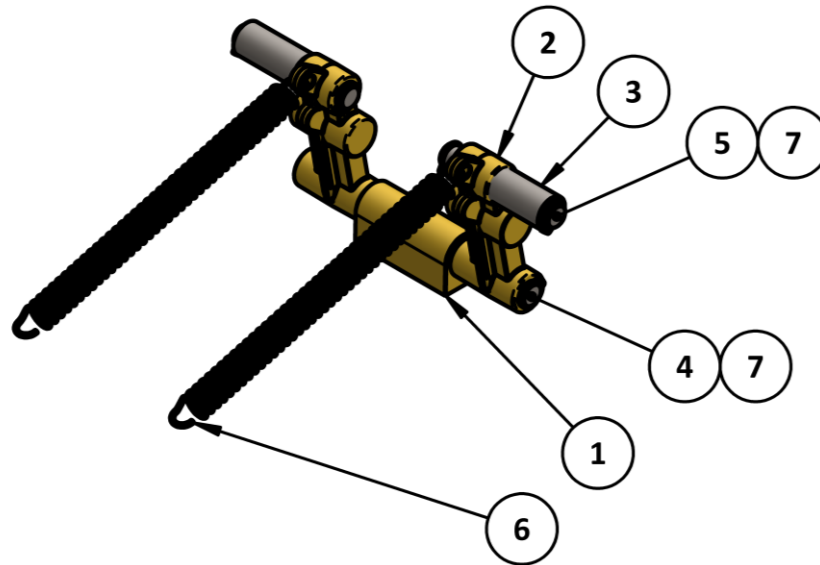

ITEM	QTY.	PART NUMBER	DESCRIPTION
1	1	2048-0005	PILLOW BLOCK; DETENT ROLLERS
2	2	2046-0010	DETENT LEVER
3	2	2048-0019	DETENT ROLLER
4	1	2048-0006	FRAME PIN
5	2	2046-0020	FRAME PIN
6	2	1202-0002	SPRING, EXTENSION, .31OD X .04 WIRE, SS
7	6	1029-1025	RETAINING RING, EXTERNAL, 1/4IN, 3100S

2048-2000 Clutch & Throttle Lever Sub-Assembly

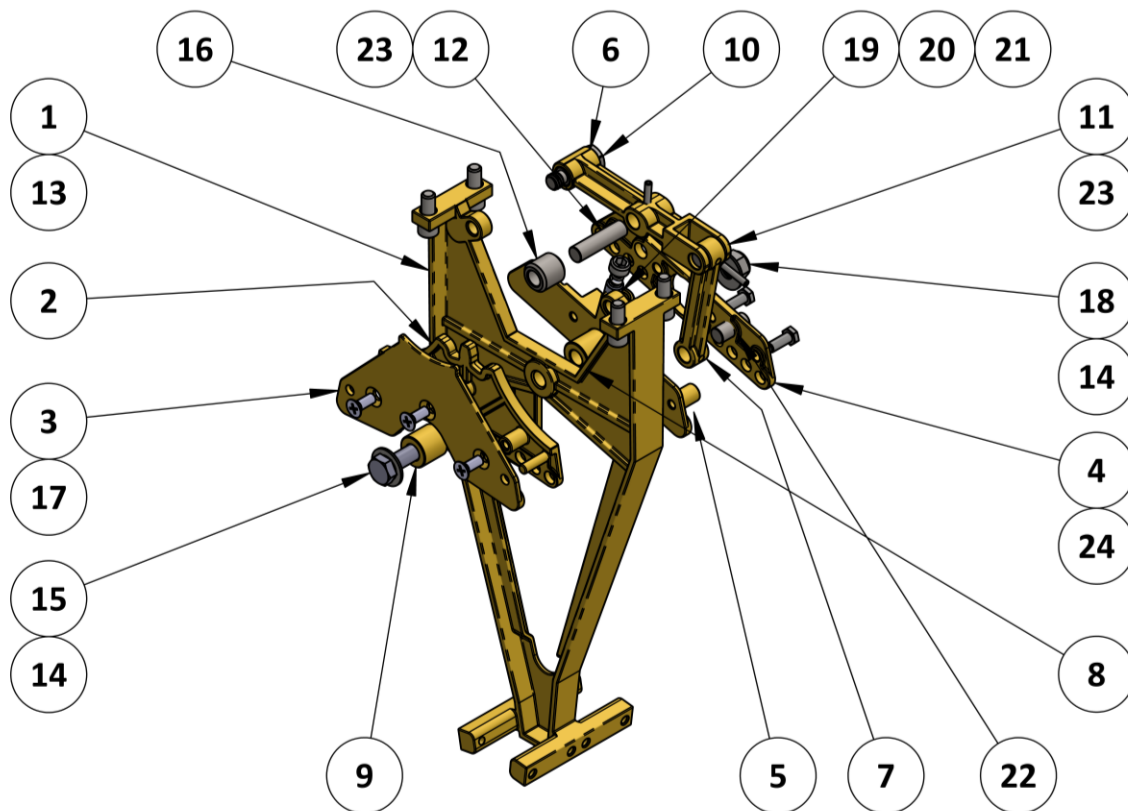

ITEM	QTY.	PART NUMBER	DESCRIPTION
1	1	2046-0005	BRACKET; PUSH-PULL CONTROL HEAD
2	1	2046-0003	PIVOT PLATE
3	1	2046-0004	RETAINER
4	1	2046-0006	RETAINER PLATE; PUSH - PULL CABLE END
5	1	2046-0007	THROTTLE CAM
6	1	2046-0008	LINK NO. 1
7	1	2046-0009	LINK NO 2
8	1	2046-0016	THROTTLE BUSHING
9	1	2046-0017	CLUTCH BUSHING
10	1	2046-0018	SHOULDER BOLT
11	1	2046-0022	LINK PIN
12	1	2046-0023	LINK SOLID PIN
13	4	1002-1010	SCREW, SKT HD CAP, 1/4-20 X 5/8, 18-8 SS
14	2	1023-0237	FLAT WASHER; 5/16, 18-8
15	1	1001-1136	SCREW, HX HD CAP, 5/16-18 X 2-1/4, 18-8
16	1	2046-0027	THROTTLE ROLLER
17	3	1009-0808	SCREW, FLAT HD, PHILLIPS, 10-24 X 1/2, 18-8
18	1	1022-0311	NUT, NYLOK, 5/16-18 UNC, 18-8
19	1	2542-0008	FRICTION PLUG
20	1	1201-0002	COMPRESSION SPRING; 1/4 DIA X 3/8 LG
21	1	1016-1204	SET SCREW - SKT; CP PT, 3/8 UNC X 1/4, 18-8
22	1	2046-0024	PIVOT PLATE PIN
23	3	1024-0510	SPRING PIN, 1/8 D X 5/8 L, 18-8
24	4	1001-0808	SCREW - HX HD MACH; #10-24 X 1/2IN, 18-8

11 APPENDIX C: INSTALLATION CUT-OUT TEMPLATE

Figure 22: Installation Cut-out Template

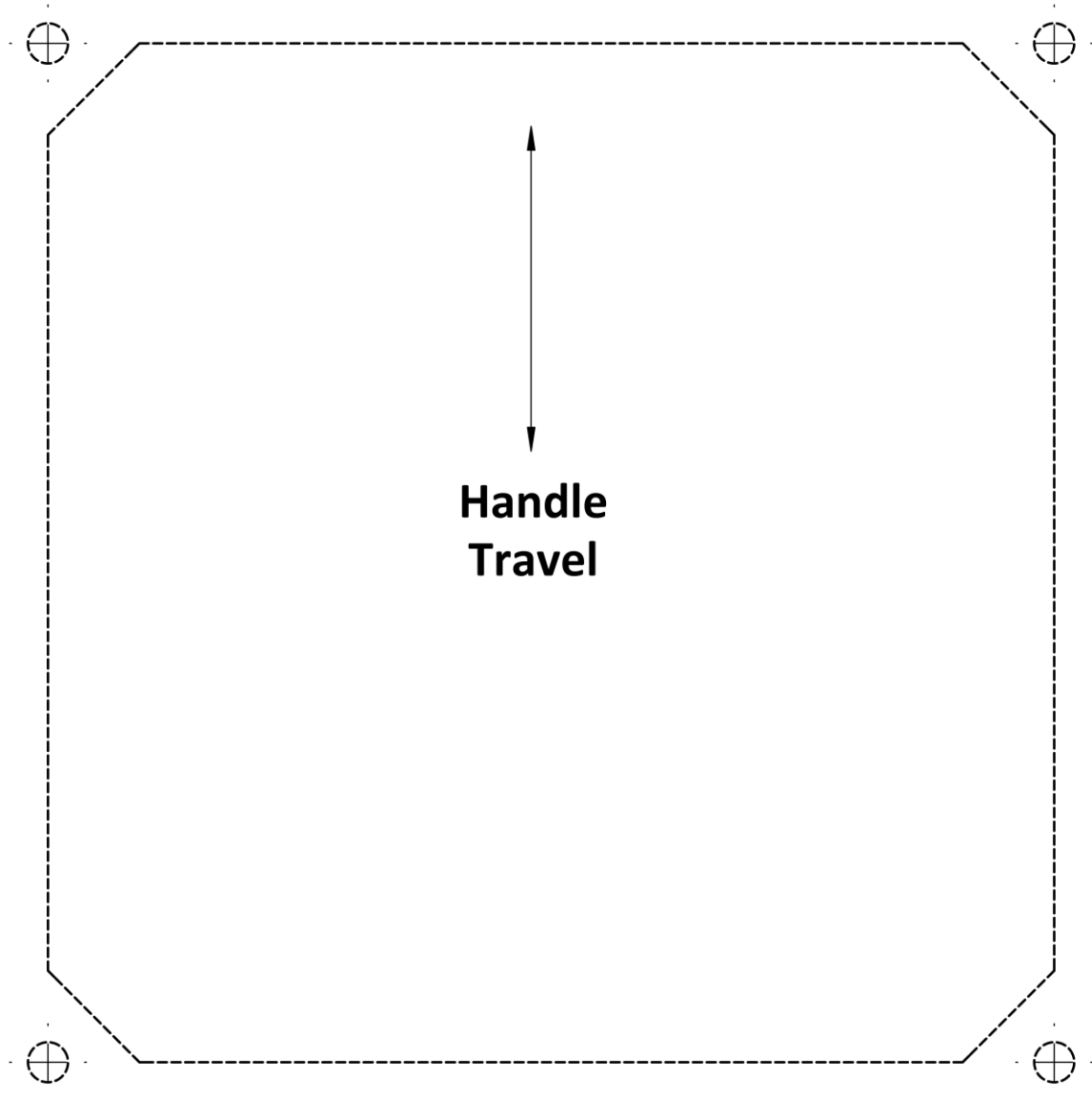
**NOTICE**

Scale may not be exactly 1:1 due to PDF and printer scaling. Verify primary dimension with a ruler after printing and before using to cut.

Reference Appendix A: Installation Dimensions, for the cut-out dimensions.

KOBELT

Kobelt Manufacturing Co. Ltd.

8238 129th Street
Surrey, British Columbia,
Canada, V3W 0A6

Sales Tel: +1-604-572-3935

Fax: +1-604-590-8313

Email: sales@kobelt.com

Website: www.kobelt.com

Made in Canada / Printed in Canada

This page intentionally blank