

KOBELT

2046 Control Head

*Owner's Operation, Installation &
Maintenance Manual*



Table of Contents

1	Introduction	4
1.1	Contact	4
1.2	Safety.....	4
1.2.1	Safety Alerts.....	4
1.2.2	Notice to Installer	4
1.2.3	Product Hazards.....	5
2	Product Description	6
2.1	Overview	6
2.2	Technical Data	7
2.3	Model Code Key	7
3	Installation	9
3.1	Receipt.....	9
3.2	Mechanical	9
3.3	Control Cable.....	9
3.3.1	Hardware	9
3.3.2	Cable Routing.....	10
3.3.3	Connection and Extension Kits	11
3.3.4	Control Head Connection.....	12
3.3.5	Actuator End Connection.....	13
3.4	Electrical	14
4	Commissioning	15
4.1	Inspection.....	15
4.2	Functional Test.....	15
5	Operation	16
6	Maintenance	16
6.1	Preventative Maintenance.....	16
6.1.1	LUBRICATION INSTRUCTIONS	16
6.2	Inspection.....	19
6.3	Recommended Spare Parts and Kits	19
6.4	Troubleshooting.....	19
7	Warranty	20
8	Revision History.....	21
9	Appendix A: Installation Dimensions	22
10	Appendix B: Parts List	23
11	Appendix C: Cut-out Template.....	27

1 INTRODUCTION

1.1 CONTACT

Kobelt Manufacturing Co. Ltd.
8238 129th Street
Surrey, British Columbia
Canada, V3W 0A6

Sales Tel: +1-604-572-3935
Fax: +1-604-590-8313
Email: sales@kobelt.com
Website: www.kobelt.com



This document is intended to clearly present comprehensive product data and provide technical information to assist the end user in design applications. Kobelt reserves the right, without notice, to change the design, or construction, of any products and to discontinue or limit distribution of any products. Kobelt also reserves the right to change, or update, without notice, any technical information contained within this document.

Kobelt recommends that customers visit our website to check for updates to this Manual. Once a product has been selected for use, it should be tested by the user to ensure proper function in all possible applications. For further instructions, please contact our distributors or visit our website.

1.2 SAFETY

1.2.1 Safety Alerts

Throughout this manual, the following symbols, and their accompanying explanation, are used to alert the user to special instructions concerning a service or operation that may be hazardous if performed incorrectly or carelessly. The associated risk levels are stated below.

 DANGER	This symbol indicates an imminently hazardous situation which, if not avoided, will result in death or serious injury.
 WARNING	This symbol indicates a potentially hazardous situation which, if not avoided, could result in death or serious injury.
 CAUTION	This symbol indicates a hazardous situation, which if not avoided, could result in minor or moderate injury.
NOTICE	This symbol informs the reader of events not related to personal injury but which there is a risk of damage to property or equipment.
SAFETY INSTRUCTIONS	This symbol informs the reader of safety-related instructions or procedures.

1.2.2 Notice to Installer

Disregarding the following safety measures can result in an accident, causing severe injury to personnel and damage to material assets.

- Only use the product as directed in this manual.
- Never put the product into service if there is evidence of visible damage.
- Never put the product into service before fully completing installation and commissioning.
- Do not carry out any modifications to the product.
- Only use authentic Kobelt spare parts.
- Observe all local regulations, directives and laws during the installation of this product.

- All installation, commissioning, and maintenance work must only be conducted by qualified personnel. (For the purpose of this manual, qualified personnel are persons who are familiar with the assembly, installation, commissioning, and operation of the product and who have the qualifications necessary for their occupation.)
- Observe all specifications in this manual. If these guidelines are not followed and damage occurs, the warranty will be voided.

1.2.3 Product Hazards

 WARNING	Equipment Starts Automatically: Vessel propulsion may activate suddenly while servicing this product, causing bodily harm. Ensure that all power sources are locked out prior to performing work.
--	---

 WARNING	Pinch Points: The 2047 control head contains pinch points, which can cause bodily harm. Ensure that hands and fingers remain clear of the pinch points when performing work.
--	--

2 PRODUCT DESCRIPTION

2.1 OVERVIEW

The Kobelt 2046 push-pull control head features single-engine control with both the clutch and throttle control integrated into one lever. More specifically, this control head is intended to control transmissions with lever type shift valves and engines with lever type throttle control. The control head also features a spring-loaded throttle override which permits running the engine with the clutch disengaged.

The 2046 is available in a combination of black and chrome, all black, or all polished chrome to suit your appearance preference. Accessories, such as neutral safety switch kits or throttle extension kits can be ordered with the units or as after market parts.

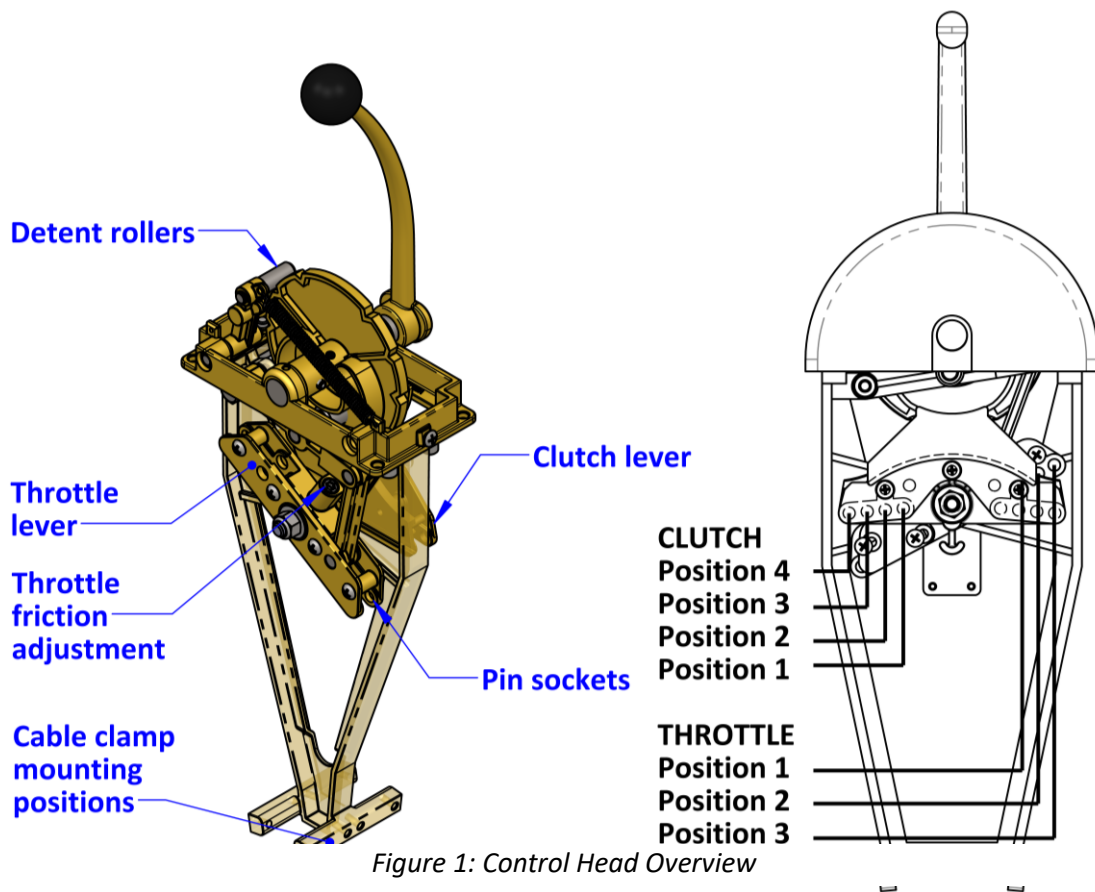

2.2 TECHNICAL DATA

Handle Travel:

- Neutral: 0° Detented
- Clutch engage: +/- 30° Detented
- Full throttle: +/- 85° -
- Over-travel:¹ 92° Detented

Pin position:	1	2	3	4
Stroke:				
• Clutch stroke:	±0.66 in [±17 mm]	±0.93 in [±24 mm]	±1.20 in [±30 mm]	±1.48 in [±38 mm]
• Throttle stroke:	0.86 in [22 mm]	1.21 in [31 mm]	1.55 in [39 mm]	1.90 in [48 mm]
Maximum Output Force ² :				
• Clutch stroke:	147 lbf [654 N]	106 lbf [472 N]	83 lbf [369 N]	68 lbf [302 N]
• Throttle stroke:	121 lbf [539 N]	90 lbf [399 N]	71 lbf [315 N]	59 lbf [261 N]
Lever ratio:				
• Clutch:	5.1:1	3.7:1	2.9:1	2.4:1
• Throttle ³ :	4.2:1	3.1:1	2.4:1	2.0:1

Ambient Temperature: -40°F...+140°F [-40 °C... + 60 °C]

Weight: 8 lbs [3.6 kg]

- 1) Forward direction only.
- 2) Estimated output force is at end of stroke based on an input force of 29 lbf on a "Tee" handle. Output force must not exceed rated cable force.
- 3) At end of stroke, lever ratio increases towards neutral.

2.3 MODEL CODE KEY

The 2047 control head can be configured in several different ways. Below is a key defining the letter code options:

2046- ← (list in alphabetical order)

Safety Options

- H = Neutral safety switch
- Blank = No safety option

Finish Options

- K = Chrome plated
- L = Polished brass
- M = Black painted dome & chrome plated handle
- Z = Metal position label

Handle Options

- U = Curved handle with knob
- V = Tee handle with plastic grip
- X = Short Tee handle
- Y = Long Tee handle

3 INSTALLATION

3.1 RECEIPT

Kobel offers the 2046 control head in several configurations [section 2.3](#)). Upon receipt of the device ensure that the number and serial number are noted on the table in page 2 manual. The serial number can be found in the location right. This model number will determine what spare parts applicable.

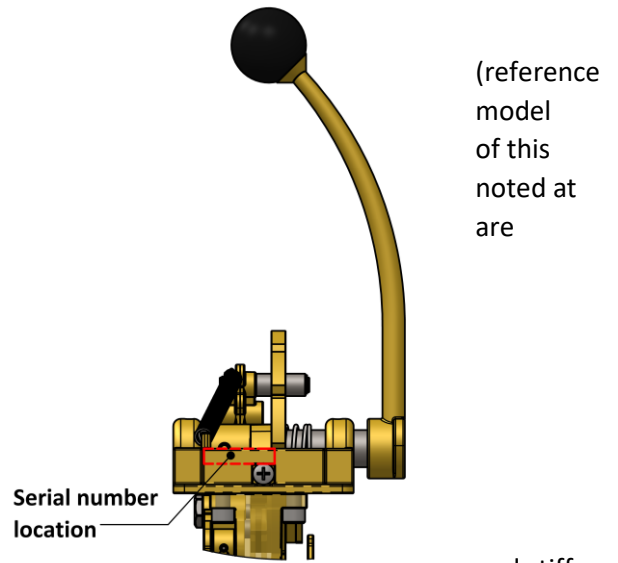

3.2 MECHANICAL

The control head must be mounted on a flat surface strong enough to withstand the cable forces listed in the [technical section](#) without excessive flexing. Choose a location that has sufficient room for the handles in both extreme positions.

The control head is equipped with (4) four clearance holes for #10 [M5] screws or bolts inserted from underneath for direct mounting to the dash. Ensure the unit is securely fastened, preferable with an anaerobic thread locker such as Loctite 243.

3.3 CONTROL CABLE

3.3.1 Hardware

The 2046 control head can be used with either 30 series or 40 series control cable. Kobelt Manufacturing does not recommend solid core cables. A solid core cable would consist of a single wire that is too stiff. Multi-stranded cores are more flexible and therefore generates less friction during operation.

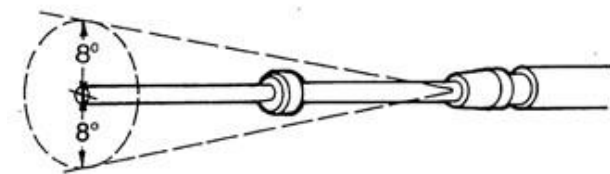

The cable ends must also be able to articulate approximately 8 degrees in either direction.

terminating the cables Kobelt recommends a ball rod end. Rod are self-aligning and therefore minimize friction and binding.

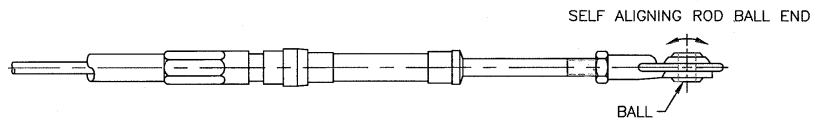

For ends

When installing hardware to the cable end, do not twist the core. If required, use a pair of pliers to hold the cable core from turning while installing the terminating hardware. When gripping the cable end, apply the pliers

immediately under the threads and take care not to score the cable rod. A scored cable rod will damage the cable seal allowing moisture and dirt to enter the casing.

3.3.2 Cable Routing

Measure the cable along the path it will take from where the cable hubs will be anchored at each end. Follow the actual cable path as closely as possible, allowing for the largest practical bend radii.

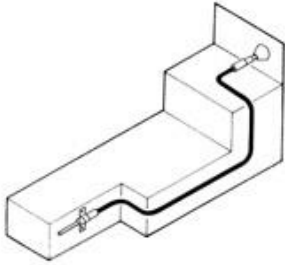

Table 1: Optimum Life Bend Radii

Do not force the cable into tighter bends than what is listed in the table

at right:

Cable Size	Minimum Radius
30 series	3 inches ¹ [76 mm]
40 series	4 inches [127 mm]
1) Solid core cables will require 6 in [152 mm] minimum bend radius.	

It is important to securely anchor the cable hubs. Any free-play in the cable clamp or mounting bracket will be perceived as lost motion or “sponginess” and will reduce the detent feel.

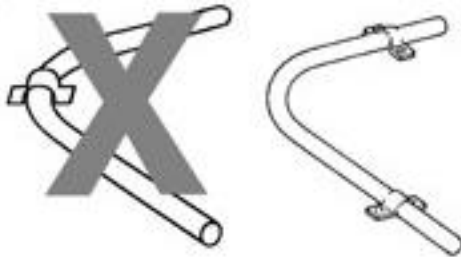

When securing the cable with clamps, it is recommended practice to position two clamps at the ends of the bend rather than one in the middle.

When installing a push-pull cable, do not kink the cable since this will permanently damage the core and casing, rendering the cable stiff and inoperable. Even minor kinks will result in premature failure.

It should also be noted to avoid routing the cable near sources of heat, such as exhaust pipes or cold, such as refrigerated fish holds.

3.3.3 Connection and Extension Kits

To install the 2046 push/pull control head, the appropriate connection kit must be purchased. Consult the table below for the correct kit:

Table 2: Connection Kits

Use Case	Kit Number
Clutch - 30 series cable	2046-0901
Clutch - 40 series cable	2046-0902
Throttle - 30 series cable	2046-0901
Throttle - 40 series cable	2046-0902

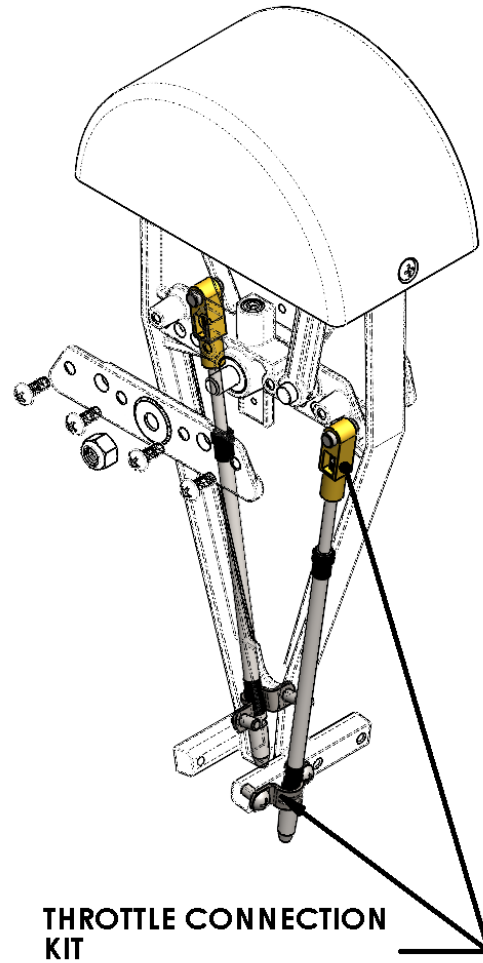
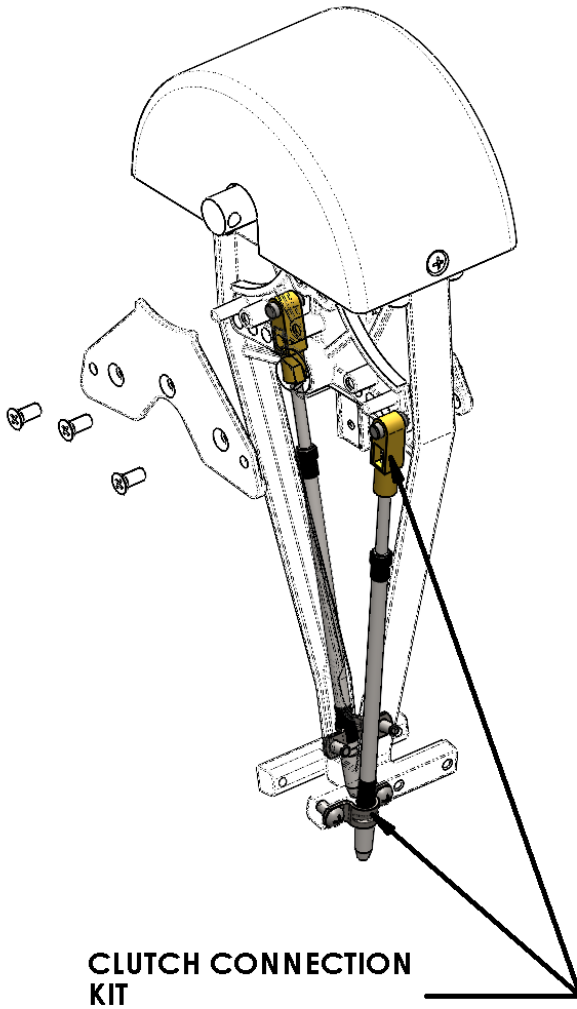

Clutch and throttle extension kits are also available for equipment that require more than the standard stroke output. Consult the table below for the correct kit part number:

Table 3: Extension Kits

Use Case	Kit Number
Clutch - 30 series cable	2046-0905
Clutch - 40 series cable	2046-0906
Throttle - 30 series cable	2046-0905
Throttle - 40 series cable	2046-0906

Note that the extension kits do not include the connection hardware.

3.3.4 Control Head Connection

The 2046 control head has a lever mechanism for actuating the clutch and the throttle that permits the cable to be installed in either push or pull.

In some marine applications with twin engines, both engines are turning in the same direction and therefore one gear box is running in the reverse to drive the propeller ahead. In this particular installation the shift cable must be connected on the opposite side of the support bracket and cam to provide the proper push and pull mode for either gear.

The clutch valve mechanism on most marine transmissions requires approximately 2¾" (70 mm) to 3" (76 mm) of travel. Consequently, the cable must be attached on the clutch lever, item "A", in the outermost hole of the support bracket (pin position 4). If the control head has insufficient stroke to properly operate the engines, then extension kits may be purchased from Kobelt Manufacturing.

To correctly install the clutch control cables, follow the steps below:

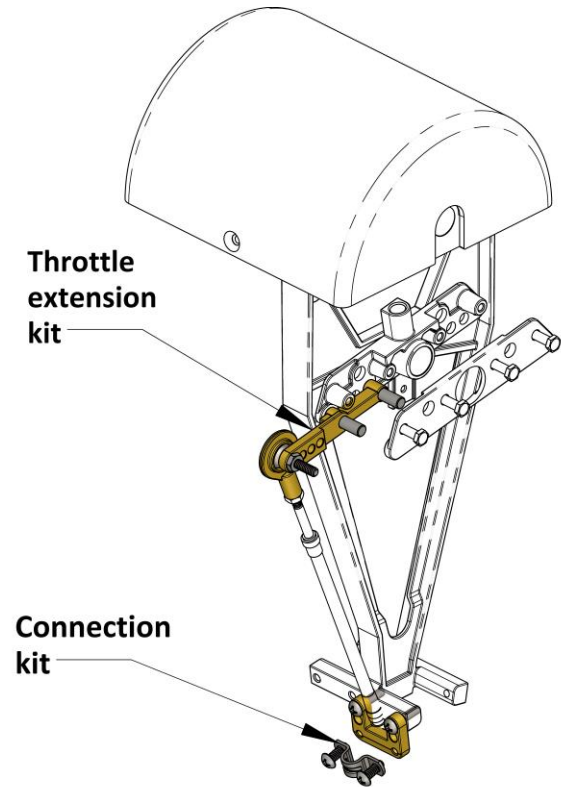

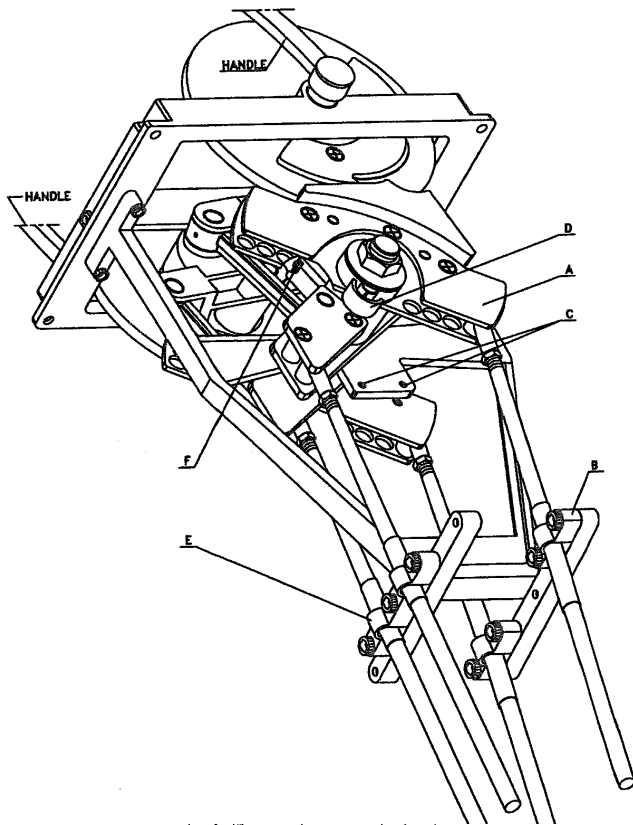

1. Secure the cables to the support bracket with the appropriate cable clamps.
2. As illustrated in the diagram below, move the control handles to the extreme forward position.
3. Ensure that the cable end extends slightly past the clutch lever attachment point (position A).
4. Move the control handles to the extreme aft position.
5. Ensure that the cable end, when in push mode, extends beyond the cable attachment point (position B).
6. If the cable end points from one extreme to the other are unequal, then the cable end fitting must be threaded out or in to correct.
7. Repeat steps 2 to 6
8. After the proper position is found, the cable end is attached to the clutch actuating pivot plate and the jam nut tightened.
9. The final step is to test that the clutch control valve goes from neutral to both forward and then reverse gear engaged positions without bottoming. A slight amount of end play is essential.

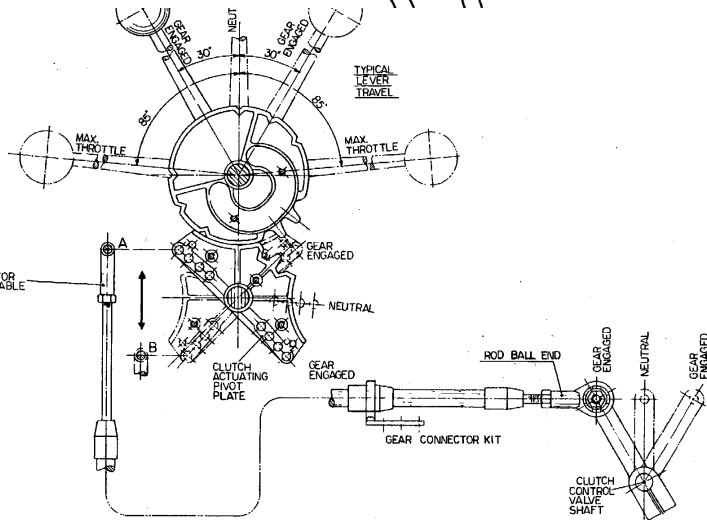

The throttle cable is installed in the same manner. In order to obtain full handle travel in the speed range, it is important to select the appropriate connection point for the adaptor kit on the throttle pivot plate.

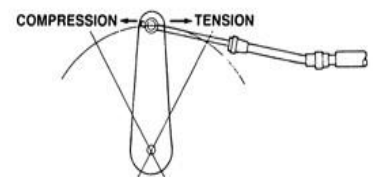

3.3.5 Actuator End Connection

When connecting the actuating end of the cable to the throttle or clutch lever, install the cable so that the greatest loads are in tension (pulling) rather than compression (pushing), if possible.

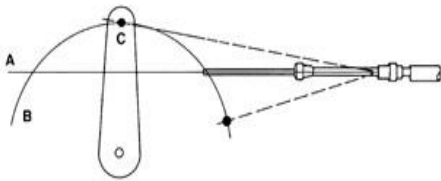

Where the cable is connected to a lever, the cable must be mounted so that it lies on a plane (A) midway on the arc (B) described by the movement of the connection point on the lever (C).

When connecting the actuating end of the cable to a spool valve such as the Kobelc 4605 servo cylinder, maximum cable life and efficiency is achieved when the cable is aligned with the lever in two planes. Reference the figure at right:

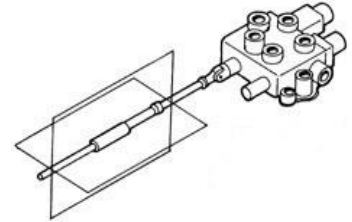

3.4 ELECTRICAL

The 2046 control head is available with an optional neutral safety switch (part number **2046-0903**). The switch kit attaches to the frame as shown on the right.

The switch is prewired with a 1 foot [305 mm] long 18 AWG wire for external connection. Connect it to an electrical junction box and the propulsion system interface.

The product's 3C/18 electrical cable contains the following wires and related functions:

Table 4: 2046 Wire Connections

2048-0903			
Wire #	Wire Name	Colour	Function
1	N.O.	RED	Switch output to signal neutral position.
2	COM	Black	COM connection.

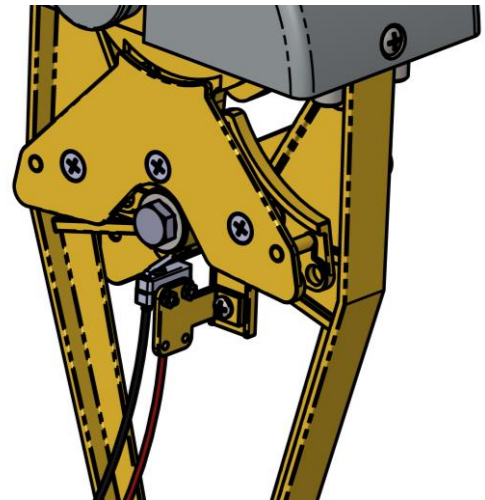

4 COMMISSIONING

4.1 INSPECTION

Before putting the control head into operation, check the cable connections at each end to ensure that there is side clearance between the sleeve and the core rod and no misalignment at either the clamp or the control head which

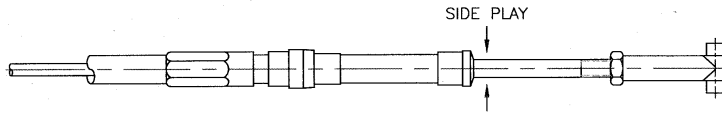

will make the cable stiff.

It is possible that a cable end may become bent either in transit or during installation. If this has occurred the cable must be replaced as it will bind between the core rod and the sleeve.

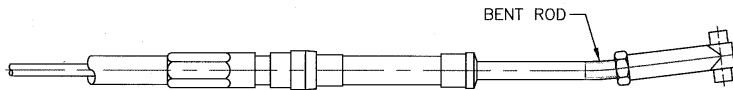

4.2 FUNCTIONAL TEST

After installation, test that the clutch control goes from neutral to both forward and then gear engaged positions without bottoming. A amount of end play is essential.

Also ensure that full speed range is obtained handle travel.

Ensure that the throttle friction adjustment is to hold the throttle position. Adjust if necessary.

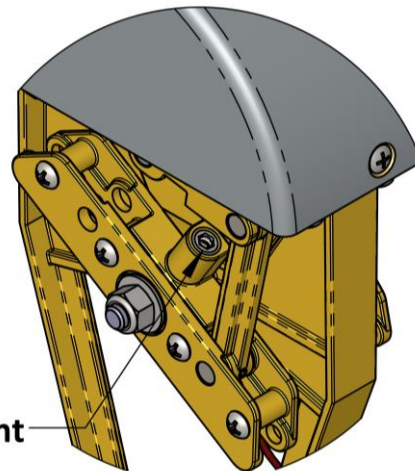

valve
reverse
slight
with full
adequate

 CAUTION	<p>Do not put the vessel into service until the control head has been tested. The Functional Test should be carried out while the vessel is still at dock.</p>
--	--

5 OPERATION

The Kobelt 2046 is equipped with a clutch bypass to permit operating the throttle without engaging the transmission into gear. To operate this feature, pull the handle outwards while in the neutral position and then operate the lever to the desired throttle position.

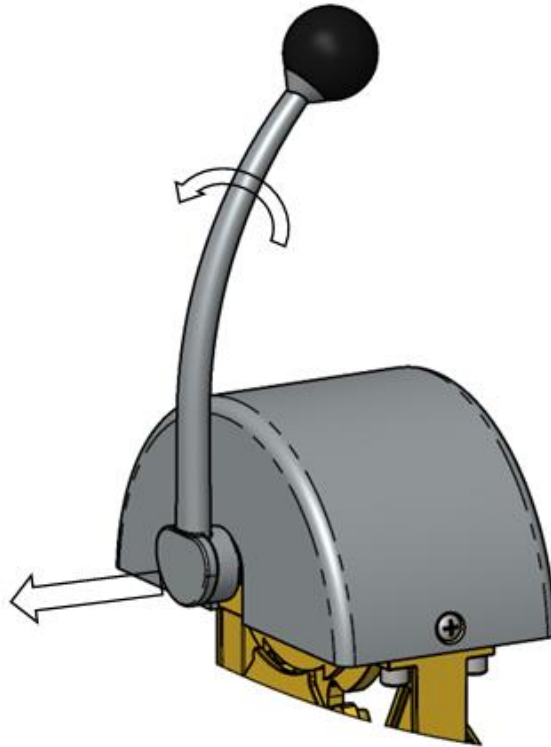

6 MAINTENANCE

6.1 PREVENTATIVE MAINTENANCE

- Quarterly (4 times per year)
 - Ensure that the throttle friction adjustment is adequate.
- Every 2 years
 - Inspect cable for wear
 - Lubricate pins & rollers
 - Inspect throttle & clutch bushings for wear

6.1.1 LUBRICATION INSTRUCTIONS

Follow the figures below to access and lubricate the bearing journals and detent tracks.

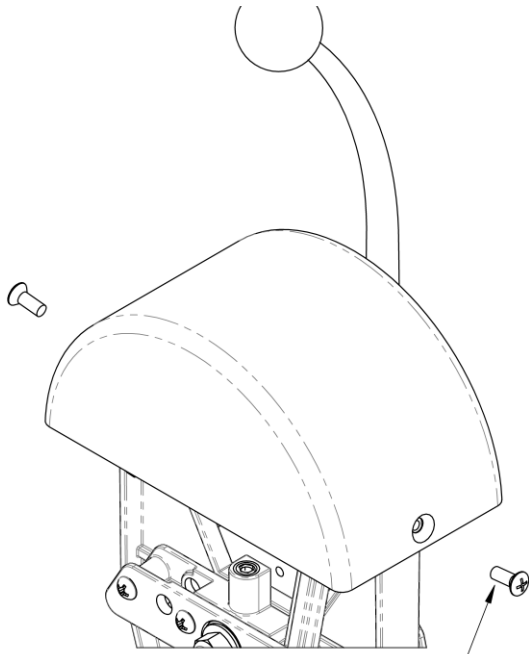

1. REMOVE THE DOME SCREWS

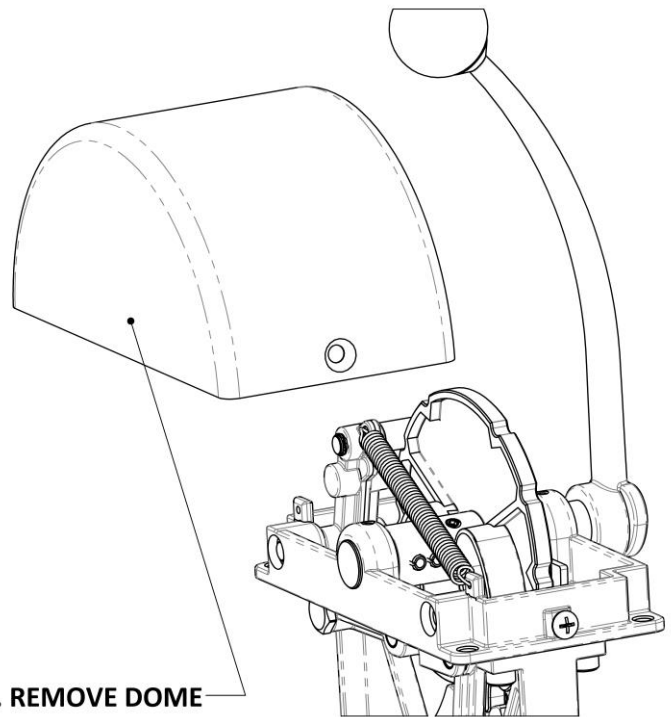

2. REMOVE DOME

3. APPLY OIL AT INDICATED LOCATIONS

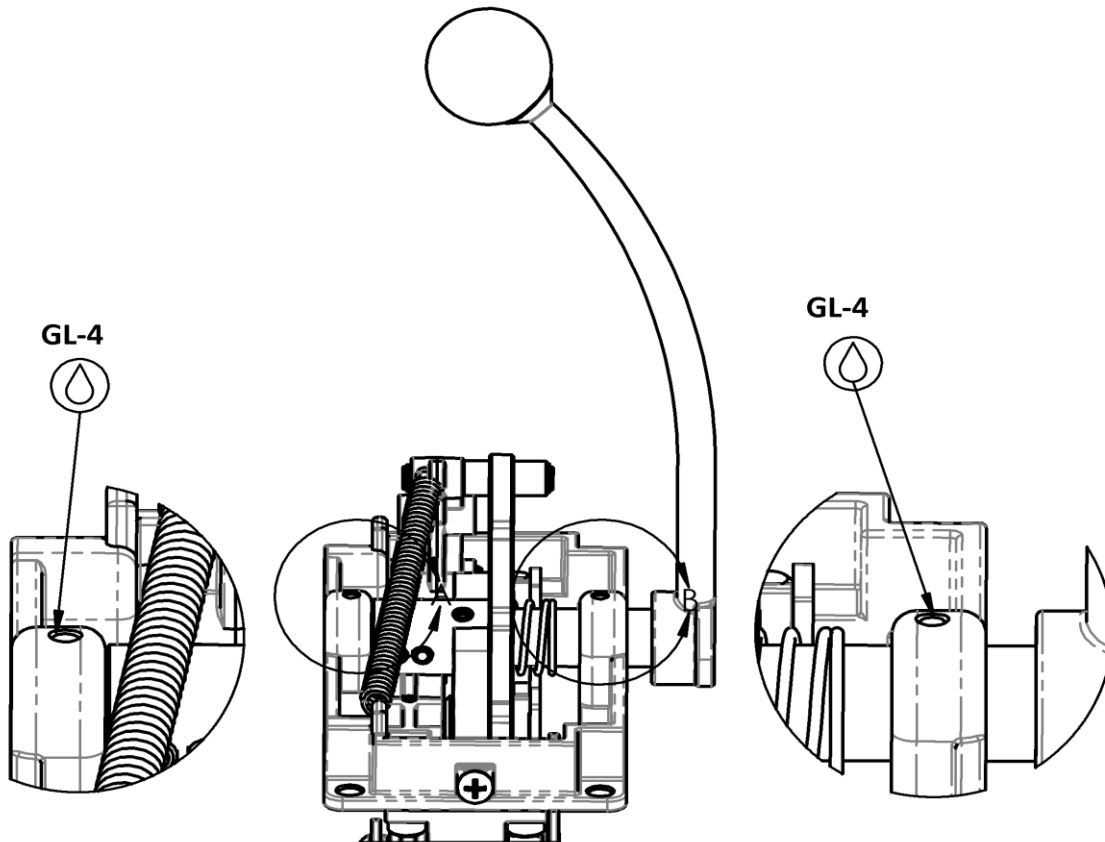

4. APPLY GREASE TO GEARS, DETENT TRACK AND ROLLER

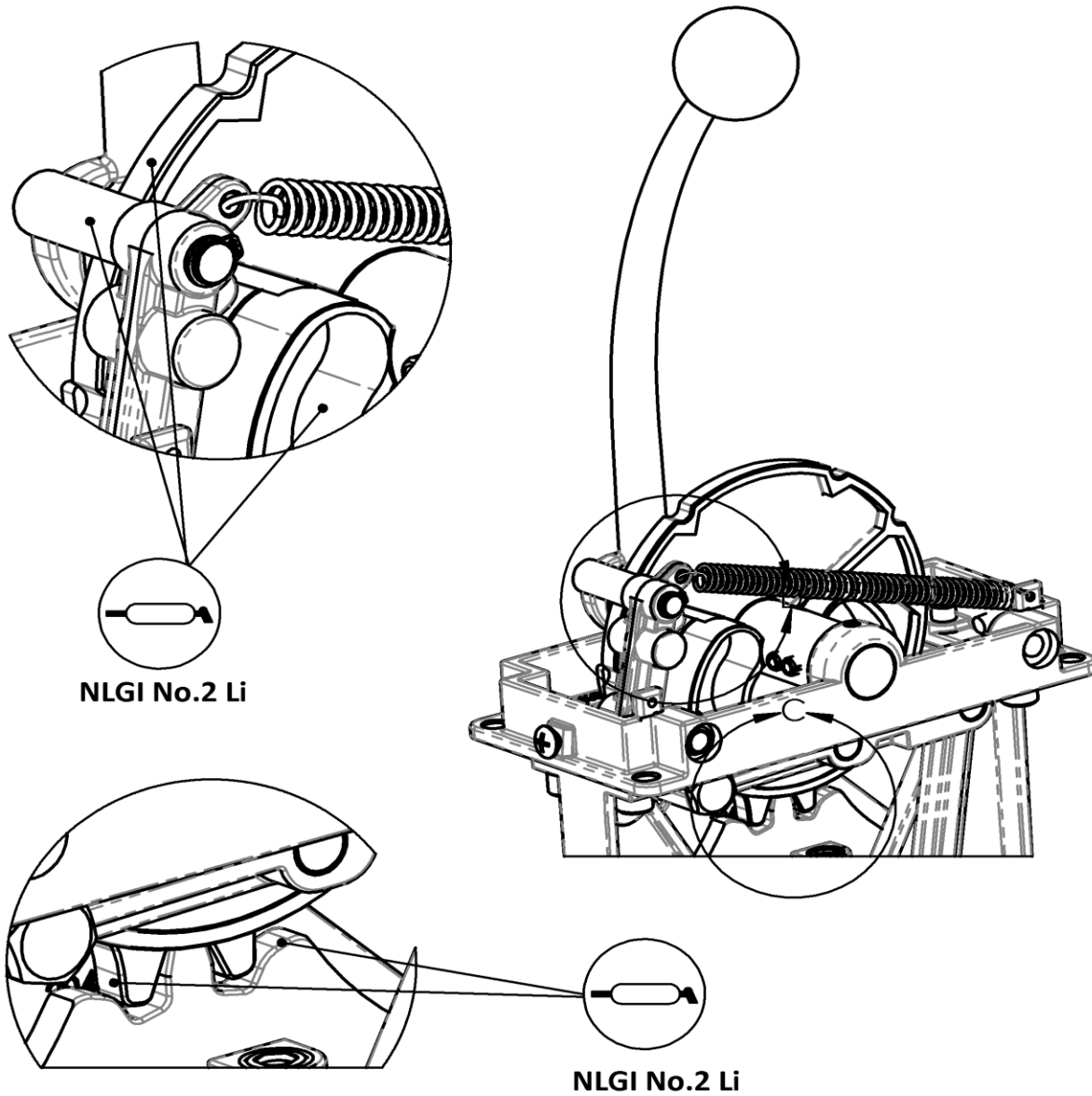
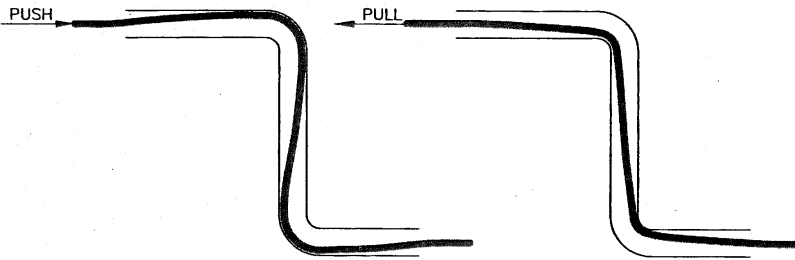

Table 5: Recommended Gear Lubricant & Grease

S. No.	Description	Grade
1	Valvoline gear oil	75w80 HD GL-4
2	Motul Transmission oil	80w-90 GL-4/GL-5
3	Phillips 66 Megaplex XD3 (Grease)	NLGI-2
4	Straplex HD 2 M5 (Grease)	NLGI-2

6.2 INSPECTION

When a cable core is pushed, it will take the longest route and, conversely, when pulled, it will take the shortest route. This appears as 'lost motion' at the actuation end. The cable stroke must be measured periodically to confirm adequate stroke.



6.3 RECOMMENDED SPARE PARTS AND KITS

The spare parts kept on hand will depend on the severity of the service. The User should monitor the condition of their control head to predict necessary spare parts and ensure they are on hand when needed.

When purchasing spare parts refer to Appendix B: Parts List at the back of this manual for Kobelt component Part Numbers.

NOTICE	It is recommended that any required service work on a Kobelt unit be performed by a factory authorized service representative. Please contact the nearest Kobelt authorized distributor for assistance.
---------------	---

6.4 TROUBLESHOOTING

If you encounter problems with the operation of your product, please refer to the trouble-shooting suggestions before contacting Kobelt for assistance. If the steps below do not resolve your issue, please reach out either Kobelt directly or our Dealers in your area.

Table 6: Common Solutions

Problem (Issue encountered)	Cause (What it means)	Corrective Action (What to do)
Full throttle not achieved	Lost motion in the cable – cable worn Lost motion in the cable – cable not clamped	1. Replace cable. 2. Clamp cable per manufacturer’s recommended practice.
Controls stiff to operate	1. Wrong cable installed. 2. Cable has been kinked. 3. Cable operating below minimum allowable temperature.	1. Replace cable with flexible core type cable. 2. Replace cable. 3. Ensure cable does not run through a fish hold.

7 WARRANTY

Kobelt Manufacturing Co. Ltd. (“Kobelt”) warrants the Products and Parts manufactured by Kobelt to be free from defects in workmanship or material and that said products are designed mechanically and functionally to perform to specifications.

This warranty is effective providing:

- The equipment is used within the intended operating conditions and in accordance with Kobelt recommendations
- The equipment is installed according to equipment diagrams, specifications and recommendations which Kobelt has provided

This warranty becomes invalid if the factory supplied serial number has been removed or altered on the product. This warranty does not cover cosmetic damage or damage caused by an act of God, accident, misuse, abuse, negligence or modification of any part of the product. This warranty does not cover damage due to improper operation or maintenance, connection to inappropriate equipment or attempted repair by anyone other than an authorized Kobelt representative.

Upon identification of a potential issue or defect with a Kobelt Product or Part, the Warranty Applicant (“Applicant”) must immediately contact Kobelt and describe the issue in writing, by letter, fax, email or other electronic conveyance. Kobelt will then assess the cause of the defect and determine warranty applicability and appropriate remediation.

If any part is found to be defective, Kobelt will replace said part FOB the Kobelt factory provided that any such defective part is returned by the Buyer with freight and applicable forwarding charges prepaid by the Buyer. Kobelt’s sole obligation to the Applicant will be to repair or replace the defective part with same or similar product, to a maximum value of the list price of the product or part. The Kobelt warranty does not cover labour charges, travel or any other associated expenses.

All Products and Parts manufactured by Kobelt, are subject to a warranty against manufacturer’s defects in materials or workmanship for a period of two (2) years from the date of purchase.

Kobelt will be responsible for all Products or Parts sold by Kobelt but manufactured by 3rd party manufacturing companies. However, these products and parts are subject to applicable 3rd party warranties and may not be the same as the Kobelt warranty.

8 REVISION HISTORY

Document Revision	Release Date	ECN	Author	Revision Summary
C	07/11/2024	01071	JS	<ul style="list-style-type: none"> Added maintenance details, section 6.1.1 Separated connection and extension kit depictions, section 3.3 Added Table 5: Recommended Gear Lubricant & Grease, Section 6.1.1
B	4/12/2024	00970	GG	<ul style="list-style-type: none"> Section 2.2 Updated technical data, to match datasheet. Added maintenance details, section 6.1 Separated connection and extension kit depictions, section 3.3 Corrected kit part numbers, section 3.4
A	-	-	-	<ul style="list-style-type: none"> Initial publication

9 APPENDIX A: INSTALLATION DIMENSIONS

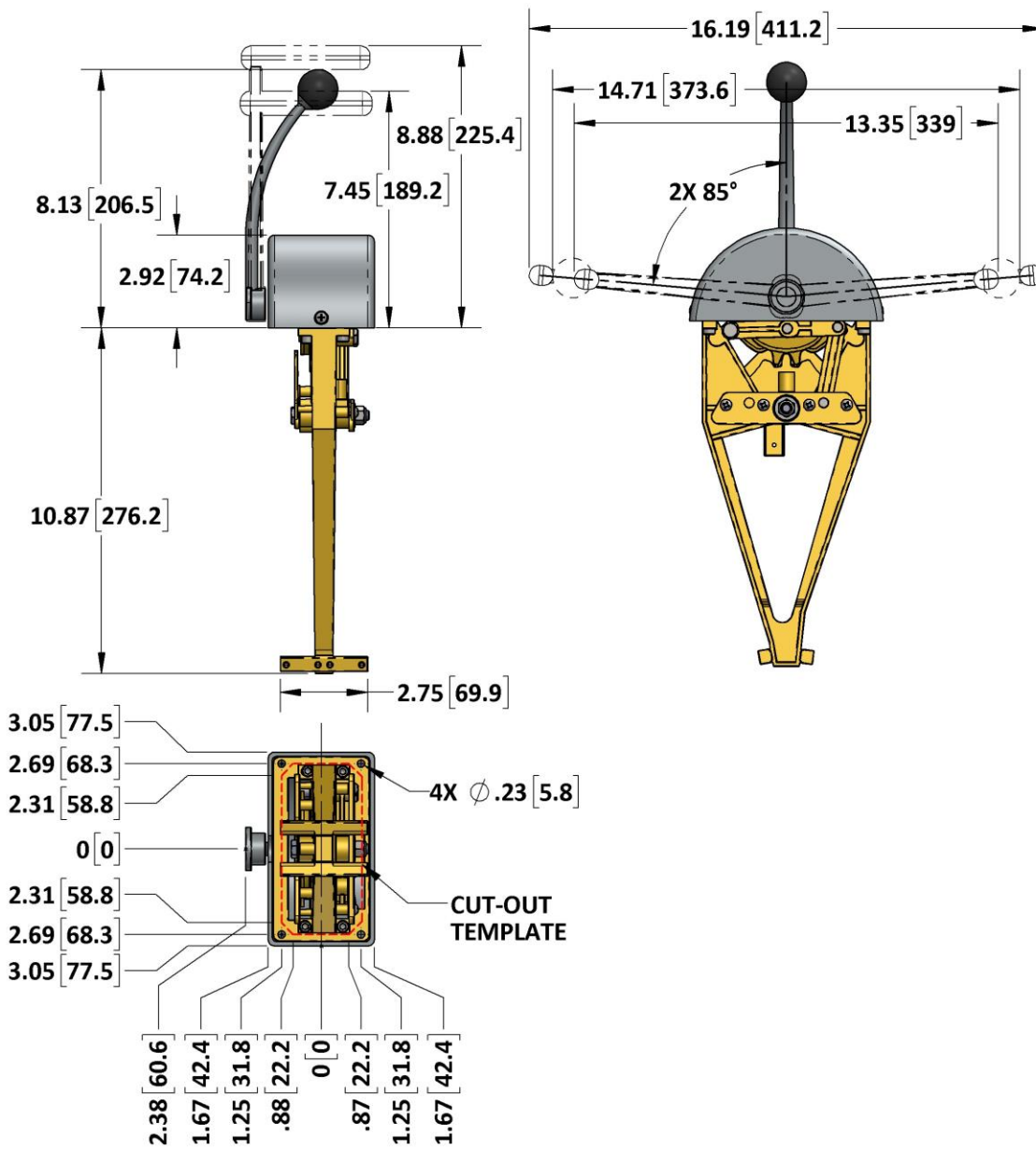
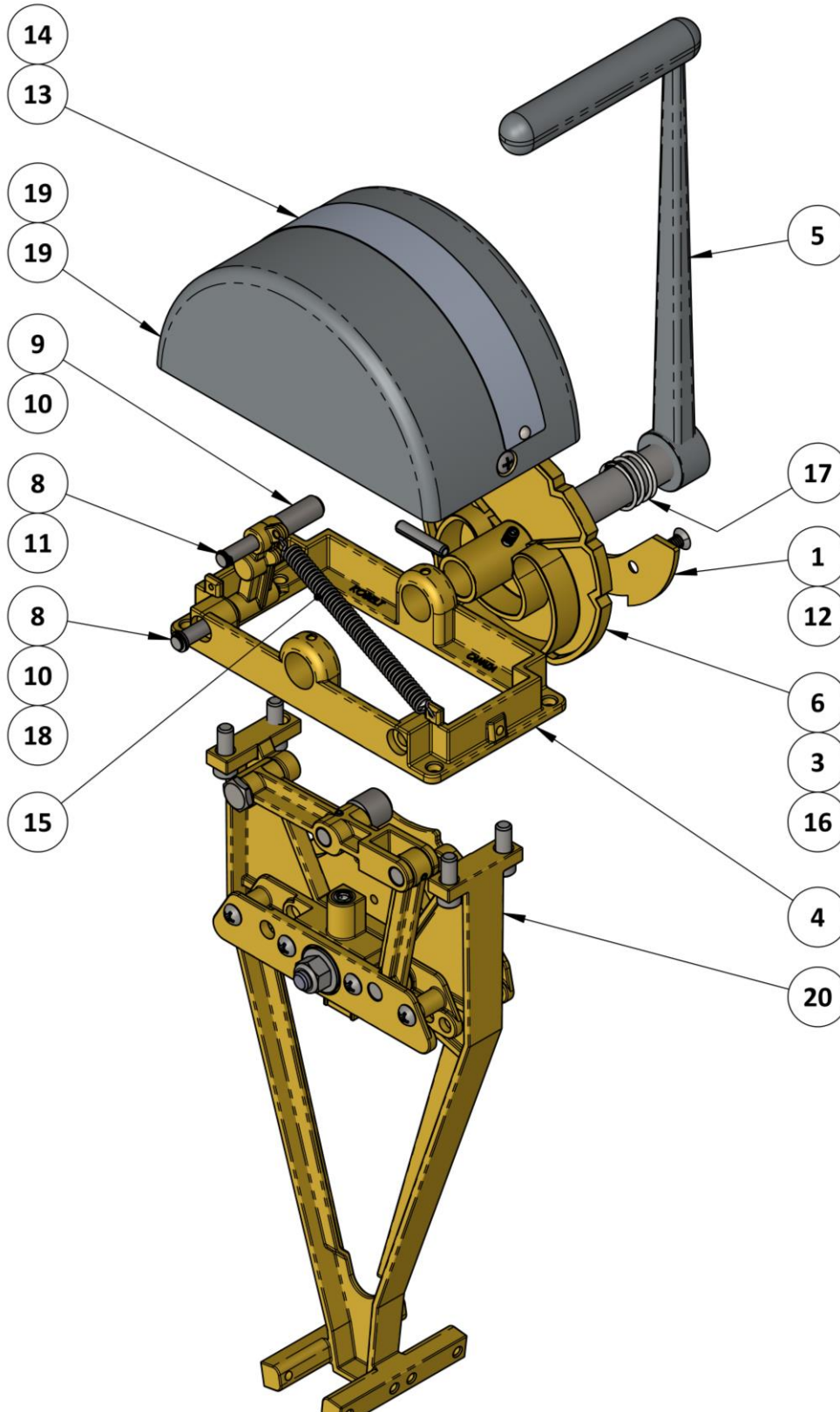

Figure 18: 2046 Installation Dimensions

10 APPENDIX B: PARTS LIST

2046-KYZ



ITEM	QTY.	PART NUMBER	DESCRIPTION
1	1	2046-0011	CAM RETAINER
2	2	1011-0808	SCREW, OVAL HD, PHL, 10-24 X 1/2, 18-8
3	1	1016-0804	SET SCREW - SKT HD CUP PT; #10-24 X 1/4 LG / 18-8
4	1	2046-0001	FRAME
5	1	2545-0014-H	HANDLE - CONTROL HEAD; LONG / CHROMED
6	1	2046-0002	CENTRE CAM
7	1	2046-0010	DETENT LEVER
8	2	2046-0020	FRAME PIN
9	1	2048-0019	DETENT ROLLER
10	2	1029-2025	2000S 1/4 EXT. CRES SNAP RINGC-0025-H
11	2	1029-1025	RETAINING RING, EXTERNAL, 1/4IN, 3100S
12	2	1009-0805	MACHINE SCREW - FLT HD PHLPS; #10 UNC X 5/16, UNDER CUT, 18-8
13	1	2046-0115	LABEL - RIVETED; ALUM FOIL
14	2	1032-0304	SCREW, U-DRIVE, #4 X 3/16, SS
15	1	1202-0002	SPRING, EXTENSION, .31OD X .041WIRE, 2.18F.L, AISI 302
16	1	1024-0816	PIN, .1875 DIAMETER
17	1	1201-0108	SPRING, COMPRESSION, .8125 X .0625 X 1.00
18	1	1023-0109	WASHER - FLAT; .255ID X .337 OD X .05 THK / 18-8
19	1	2004-0002-K	DOME - CONTROL HEAD; CHROME FINISH
20	1	2046-2000	BRACKET SUB-ASSEMBLY

2046-2000 Bracket Sub-Assembly

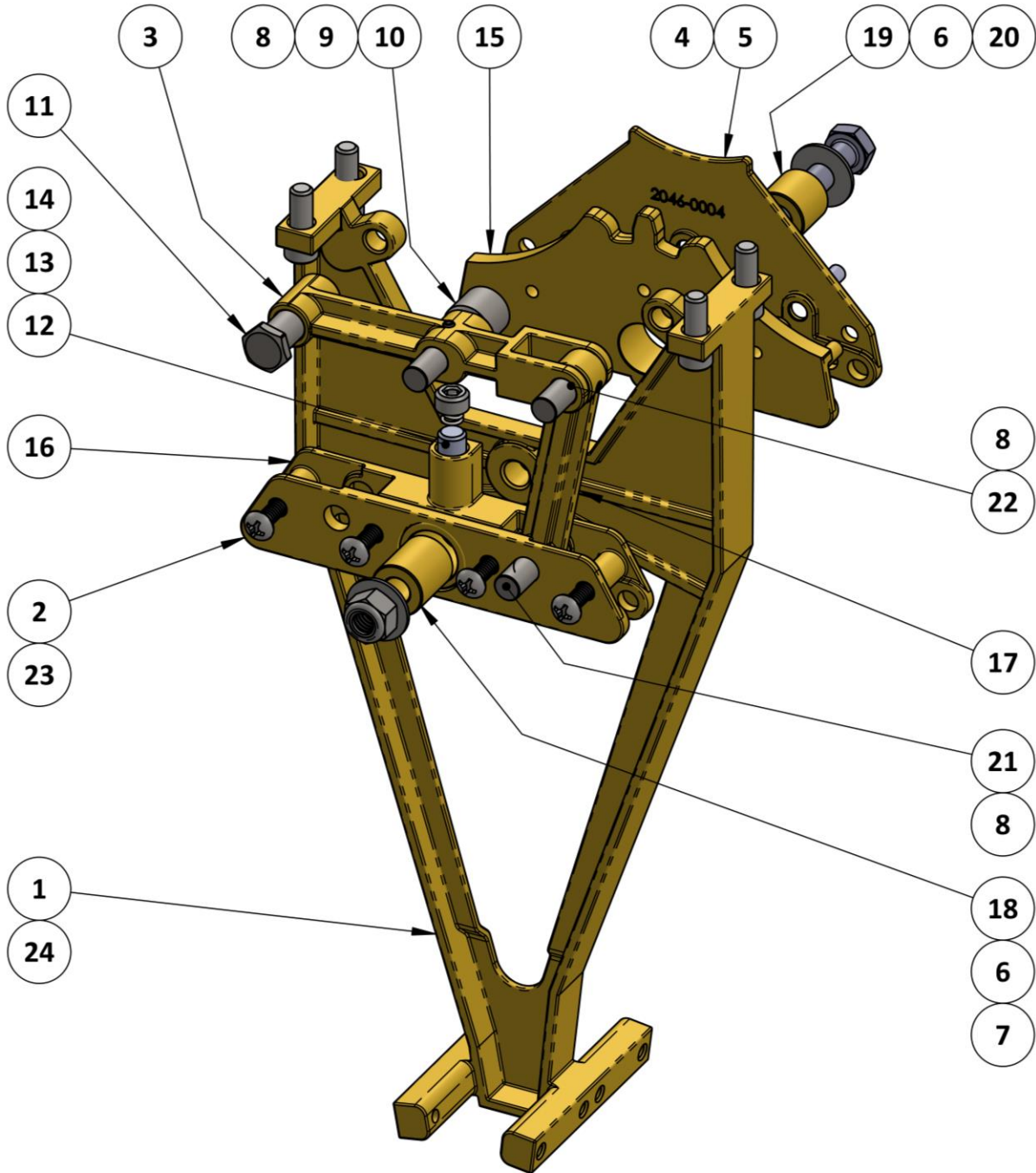

ITEM	QTY.	PART NUMBER	DESCRIPTION
1	1	2046-0005	BRACKET; PUSH-PULL CONTROL HEAD
2	1	2046-0006	RETAINER PLATE; PUSH - PULL CABLE END
3	1	2046-0008	LINK NO. 1
4	3	1009-0808	SCREW, FLAT HD, PHILLIPS, 10-24 X 1/2, 18-8
5	1	2046-0004	RETAINER
6	2	1023-0237	FLAT WASHER; 5/16, 18-8
7	1	1022-0311	NUT, NYLOK, 5/16-18 UNC, 18-8
8	3	1024-0509	SPRING PIN, 1/8 X 9/16, AISI 420
9	1	2046-0023	LINK SOLID PIN
10	1	2046-0027	THROTTLE ROLLER
11	1	2046-0018	SHOULDER BOLT
12	1	2542-0008	FRICTION PLUG
13	1	1201-0002	COMPRESSION SPRING; 1/4 DIA X 3/8 LG
14	1	1016-1204	SET SCREW - SKT; CP PT, 3/8 UNC X 1/4, 18-8
15	1	2046-0003	PIVOT PLATE
16	1	2046-0007	THROTTLE CAM
17	1	2046-0009	LINK NO 2
18	1	2046-0016	THROTTLE BUSHING
19	1	2046-0017	CLUTCH BUSHING
20	1	1001-1136	SCREW, HX HD CAP, 5/16-18 X 2-1/4, 18-8
21	1	2046-0024	PIVOT PLATE PIN
22	1	2046-0022	LINK PIN
23	4	1010-0808	SCREW, RND HD PHIL, #10-24 X 1/2, 18-8 SS
24	4	1002-1010	SCREW, SKT HD CAP, 1/4-20 X 5/8, 18-8 SS

11 APPENDIX C: CUT-OUT TEMPLATE

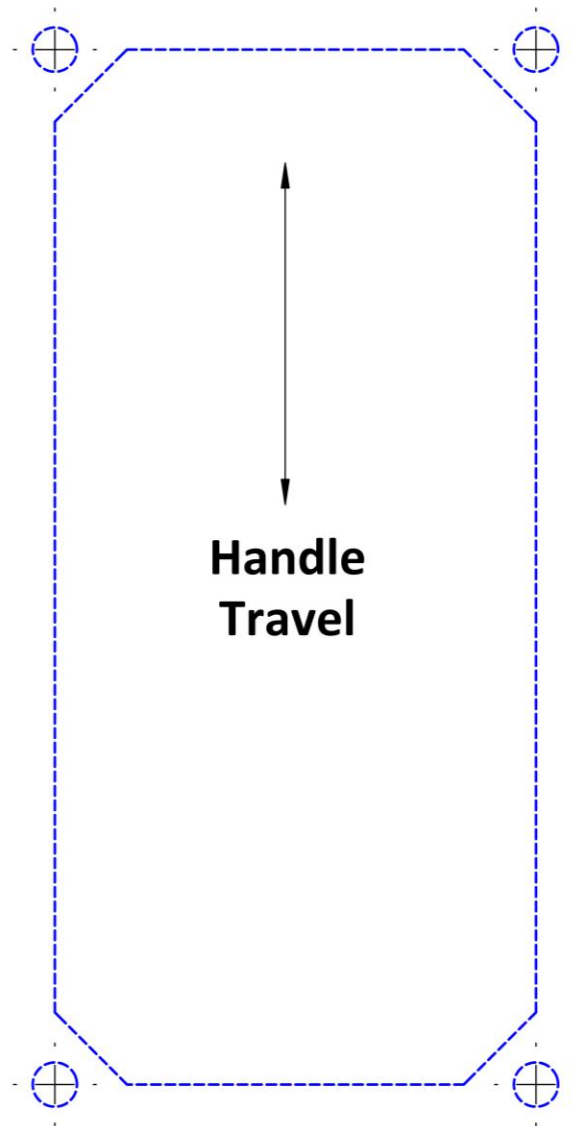

NOTICE	Scale may not be exactly 1:1 due to PDF and printer scaling. Verify primary dimension with a ruler after printing and before using to cut.
---------------	--

Reference [Appendix A: Installation Dimensions](#), for the cut-out dimensions.



Kobelt Manufacturing Co. Ltd.
8238 129th Street
Surrey, British Columbia,
Canada, V3W 0A6

Sales Tel: +1-604-572-3935
Fax: +1-604-590-8313
Email: sales@kobelt.com
Website: www.kobelt.com

Made in Canada / Printed in Canada

Kobelt Manufacturing Co. Ltd.