

Picture shows 6527 actuator with cable (not included in standard unit)

Model 6527 Electronic Actuator

The 6527 electronic actuators are constructed in bronze and stainless steel, except for the motor and worm. It can be used for many marine and industrial applications to operate and position lever actuated mechanisms. The basic control unit comes with manual override and one trim pot per side for adjusting the stroke. This actuator does not have an internal resilient link like our Model 6524. Therefore, the stroke must be adjusted precisely to suit the device to be controlled. This unit has a high torque of 180 in-lbs.

Note: This actuator is not waterproof and therefore should not be immersed in liquid or washed.

The actuator comes with two 43-series connection kits. 30 series connection kits are also available upon request.

Weight (approx.): 24 lb. (11 kg)

Please visit our website www.kobelt.com for more information.

MODEL 6527

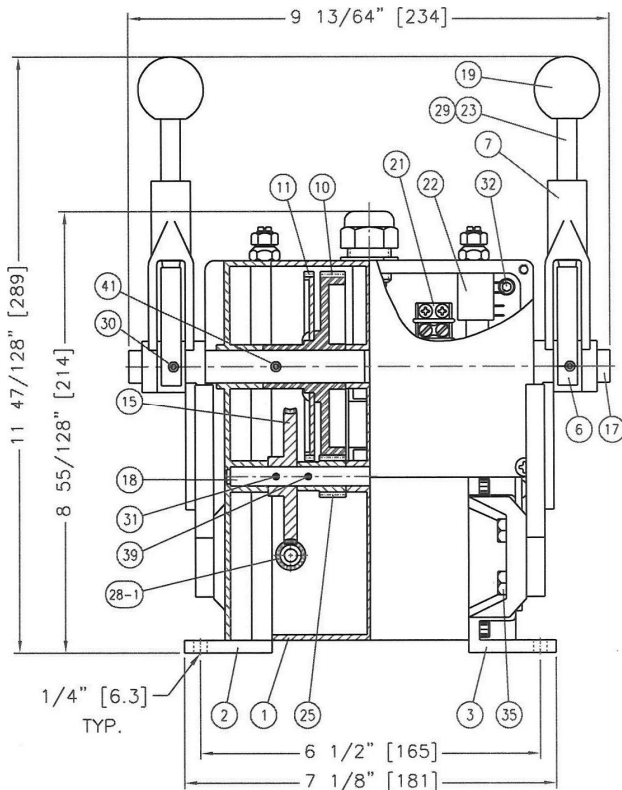
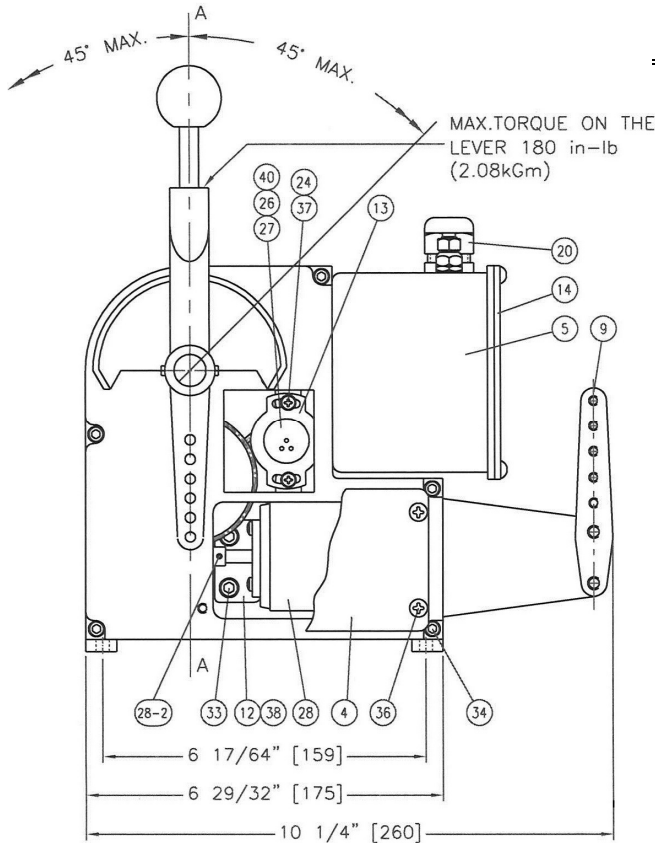

Item	Qty	Part Number	Description
1	1	6527-0001	Centre Housing
2	1	6527-0002	Side Housing
3	1	6527-0003	Side Housing
4	2	6527-0004	Cover
5	1	6527-0005	Connection Housing
6	2	6527-0006	Disconnect Cam
7	2	6527-0007	Disconnect Arm
9	2	6527-0009	Stationary Arm
10	2	6527-0010	Spur Gear
11	2	6527-0011	Feedback Gear
12	1	6527-0012	Motor Bracket, right
13	2	6524-0013	Potentiometer Bracket
14	1	6527-0014	Cover
15	2	6527-0015	Worm Pinion
17	2	6527-0017	Shaft - Long
18	2	6527-0018	Shaft
19	2	2030-0001	Knob Black
20	1	6001-0249	Connecting Gland
21	2	6009-0008	Terminal Block, Cinch 8-140
22	2	6002-4000	Trim Pot - 1K
23	2	6524-0015	Handle
24	4	1023-0106	Flat Washer
25	2	6524-0021	Pinion
26	2	6524-0022	Potentiometer Drive Gear
27	2	POT-6	Potentiometer - 5K, vp
† 28	2	Motor-14201	Motor Pittman 24VDC
28-1	2	6524-0019	Worm
28-2	2	1024-0406	Spring Pin
29	2	1201-0140	Spring
30	2	1024-0818	Spring Pin
31	2	1024-0512	Spring Pin
32	4	1002-0806	Socket Hd Cap Screw
33	4	1002-1008	Socket Hd Cap Screw
34	10	1002-0808	Socket Hd Cap Screw
35	4	1001-1012	Hex Hd Machine Screw
36	22	1010-0806	Round Hd Philips Screw
37	20	1012-0606	Pan Hd Philips Screw
38	1	6527-0012A	Motor Bracket, left
39	2	1024-0509	Spring Pin
40	2	1016-0602	Set screw
41	2	1024-0814	Spring Pin
<u>Cable Connection Kit (not shown)</u>			
42	4	1010-0810	Round Hd Philips Screw
43	2	2144-3	Rod End
44	2	1001-0814	Hex Bolt
45	2	1023-0108	Flat Washer
46	2	1023-0308	Lock Washer
47	2	1022-0108	Hex Nut
48	2	1022-0260	Jam Nut
49	2	2108-0002	Cable Clamp, 43 series

* Quantity may vary

† To order spare part, use 6527-1028 for motor with gear

All dimensions in inches (mm)